

Exploded View and Part Identification ----- 3.3

Stile, Rail and Reinforcement Block Locations ----- 3.24

90-Minute Steel Fire Door Reinforcement Locations ----- 3.26

Door Slab Trimming ----- 3.27

Door Slab Resizing ----- 3.28

Fire Door Slab Resizing ----- 3.32

Slab Repair ----- 3.33

Hinge Preparation (Except 90-Minute Steel Fire Door) ----- 3.37

Lock Preparation (Except 90-Minute Steel Fire Door) ----- 3.41

Lock Preparation 90-Minute Steel Fire Door ----- 3.43

Multipoint Lock Preparation ----- 3.45

Classic-Craft & Smooth Star 300 Panel Installation ----- 3.49

Doorlite and Panel Preparation ----- 3.51

Doorlite & Designline Panel Installation ----- 3.53

Flush Fit Frame Installation ----- 3.58

Impact Doorlite Installation ----- 3.59

Hinge Installation ----- 3.60

Door Bottom Selection and Installation ----- 3.63

Grille Installation ----- 3.66

Classic Craft American Style Divider Installation ----- 3.68

Smooth Star - Fiber Classic Divider Installation ----- 3.70

Classic Craft Dentil Shelf Installation ----- 3.72

Fiber Classic - Smooth Star Dentil Shelf Installation ----- 3.74

Special Shop Painting ----- 3.75

Special Shop Machining ----- 3.76

Rain Deflector Installation ----- 3.77

Decorative Hinge Strap Application ----- 3.78

DOOR
PREP

The following pages show exploded views of Therma-Tru door slabs. All Therma-Tru door slabs (except flush-glazed Fiber-Classic and Smooth-Star doors with Low-E glass, or bevelline glass) are reversible for handing and swing. Mounting hardware, components, and accessories will hand the door. Make sure to have a clear understanding of handing before proceeding. See the illustrations below for determining the handing of a door.

DOOR
PREP

INSWING

(View from inside building)

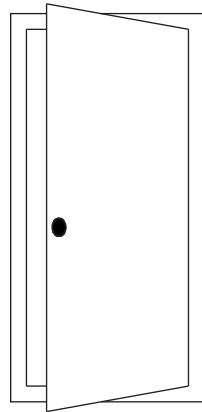

Left-Handed

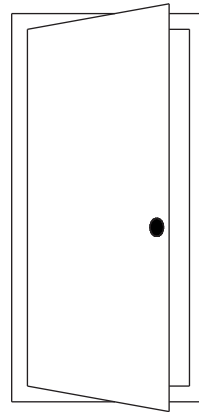

Right-Handed

OUTSWING

(View from outside building)

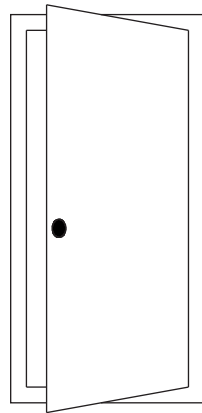

Left-Handed

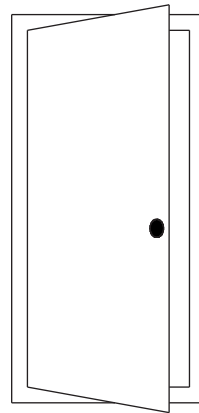

Right-Handed

DOOR
PREP

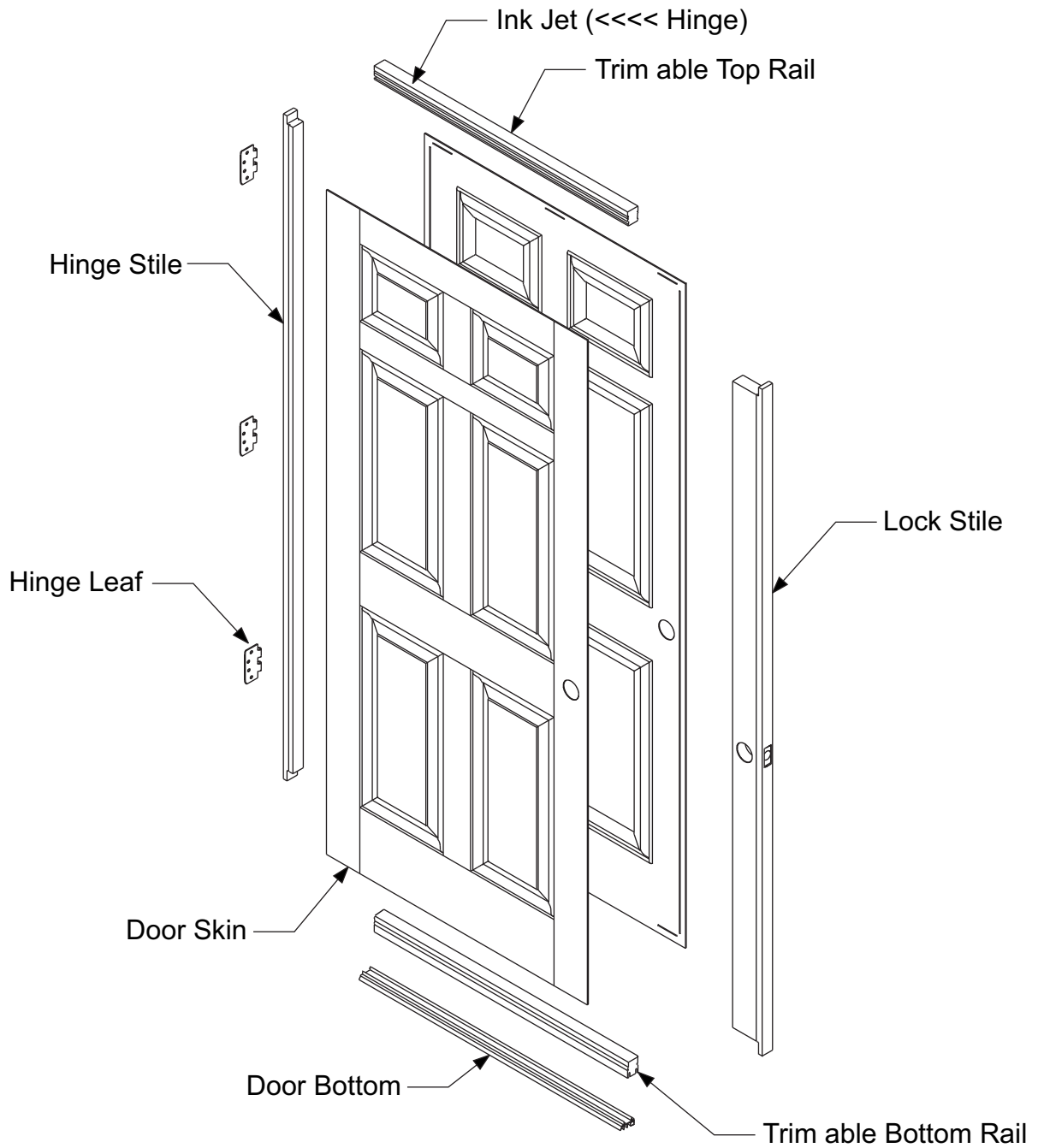

Classic-Craft

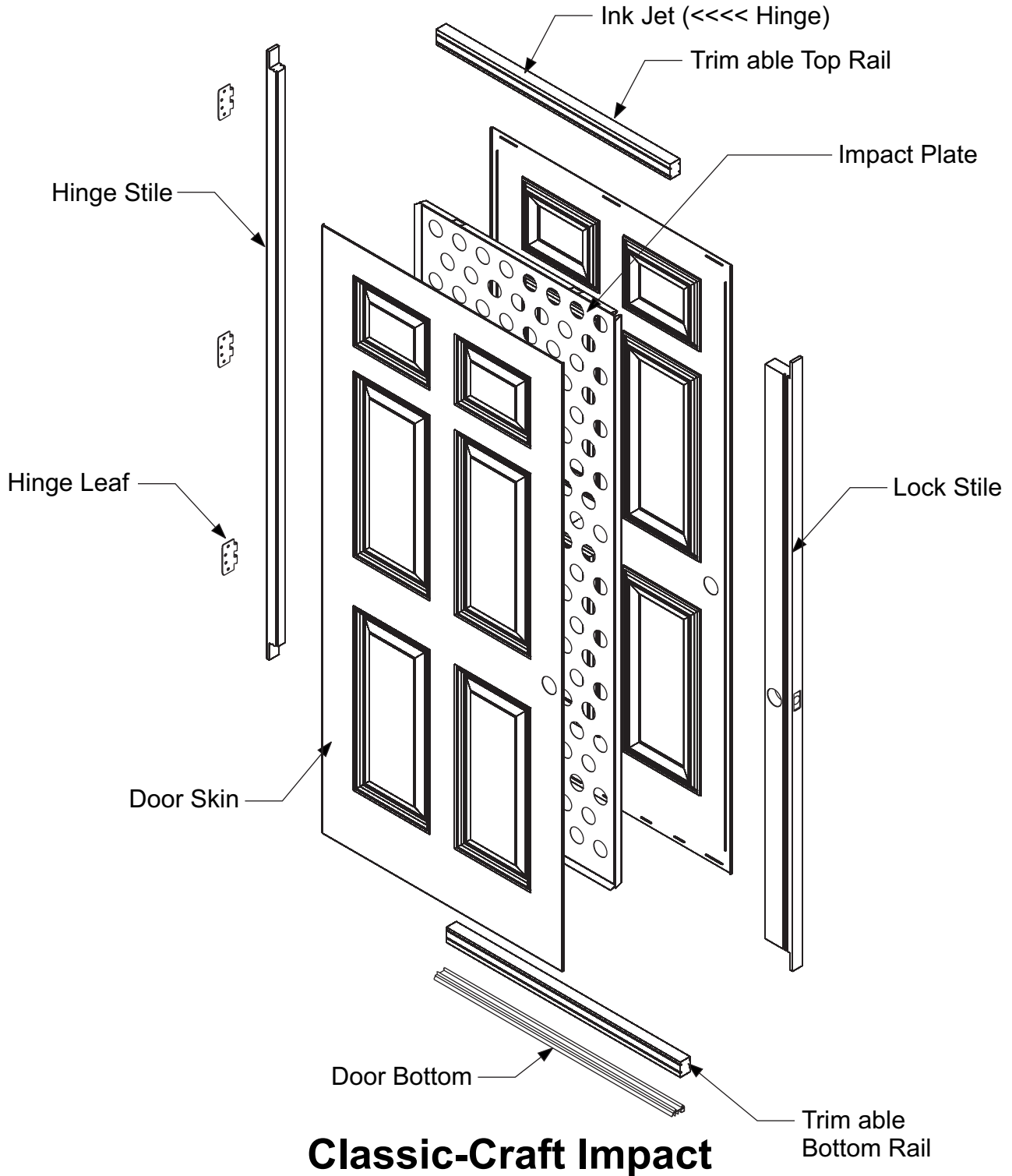

DOOR
PREP

Classic-Craft Impact

DOOR
PREP

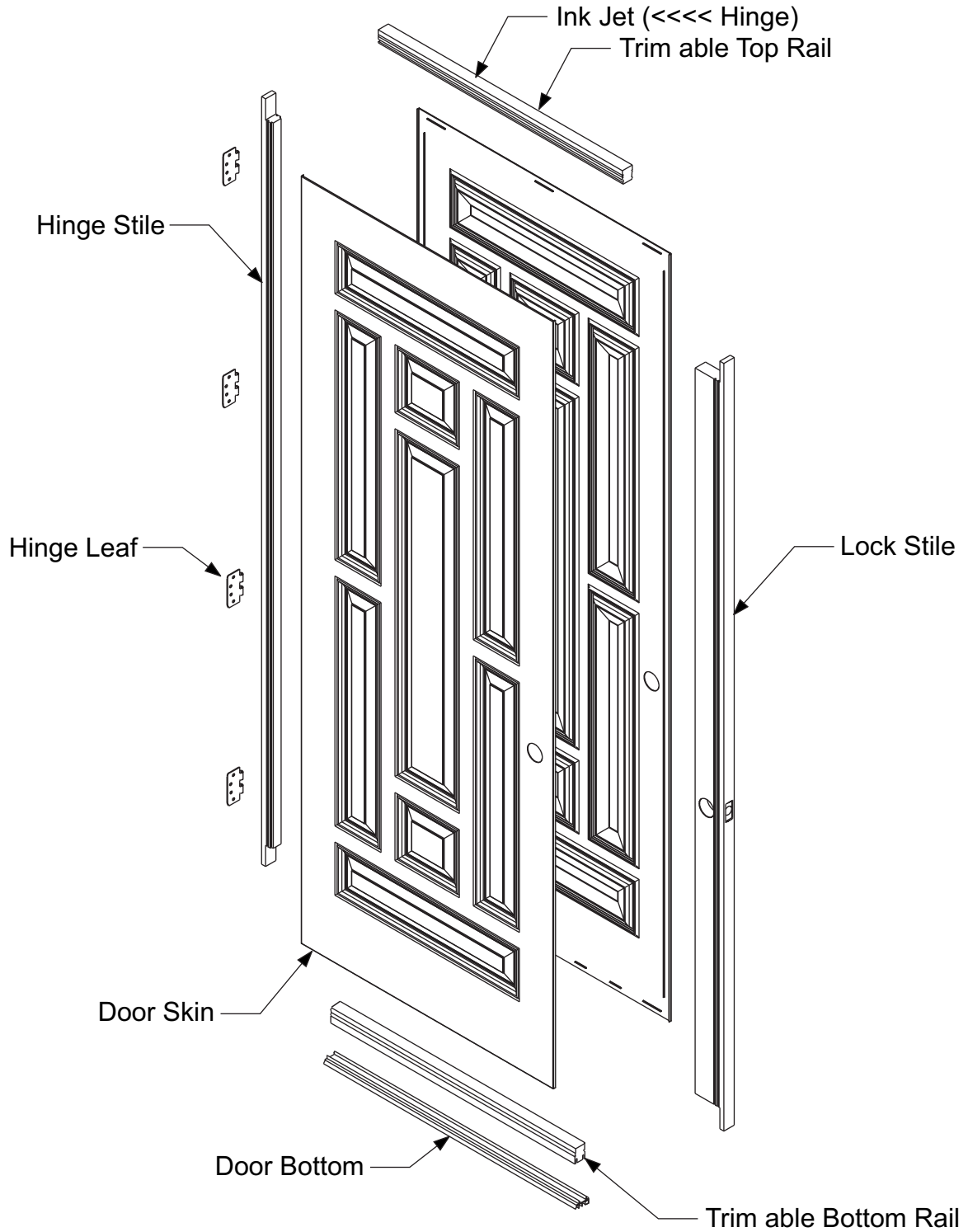

8/0 Classic-Craft

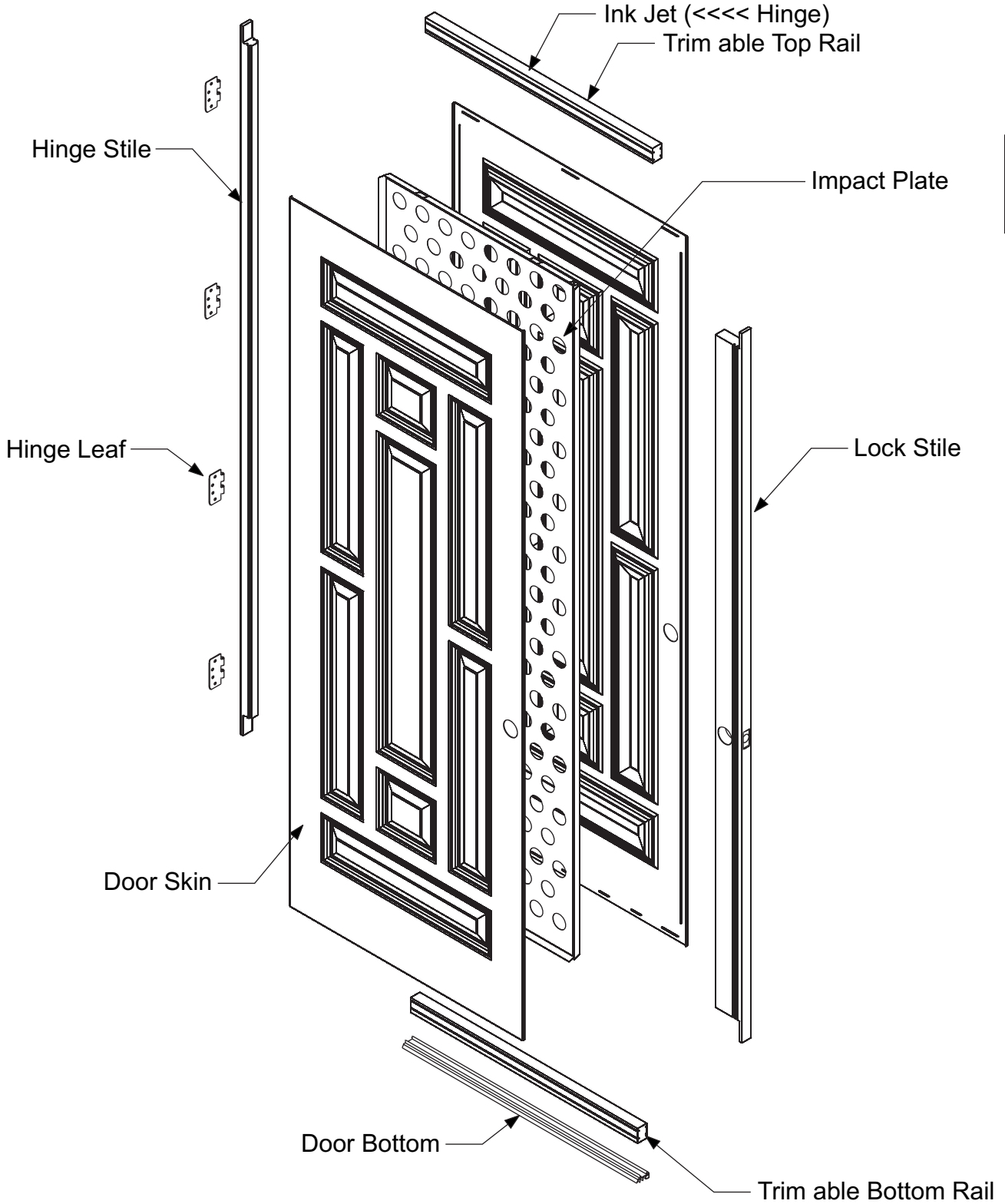

DOOR
PREP

8/0 Classic-Craft Impact

DOOR
PREP

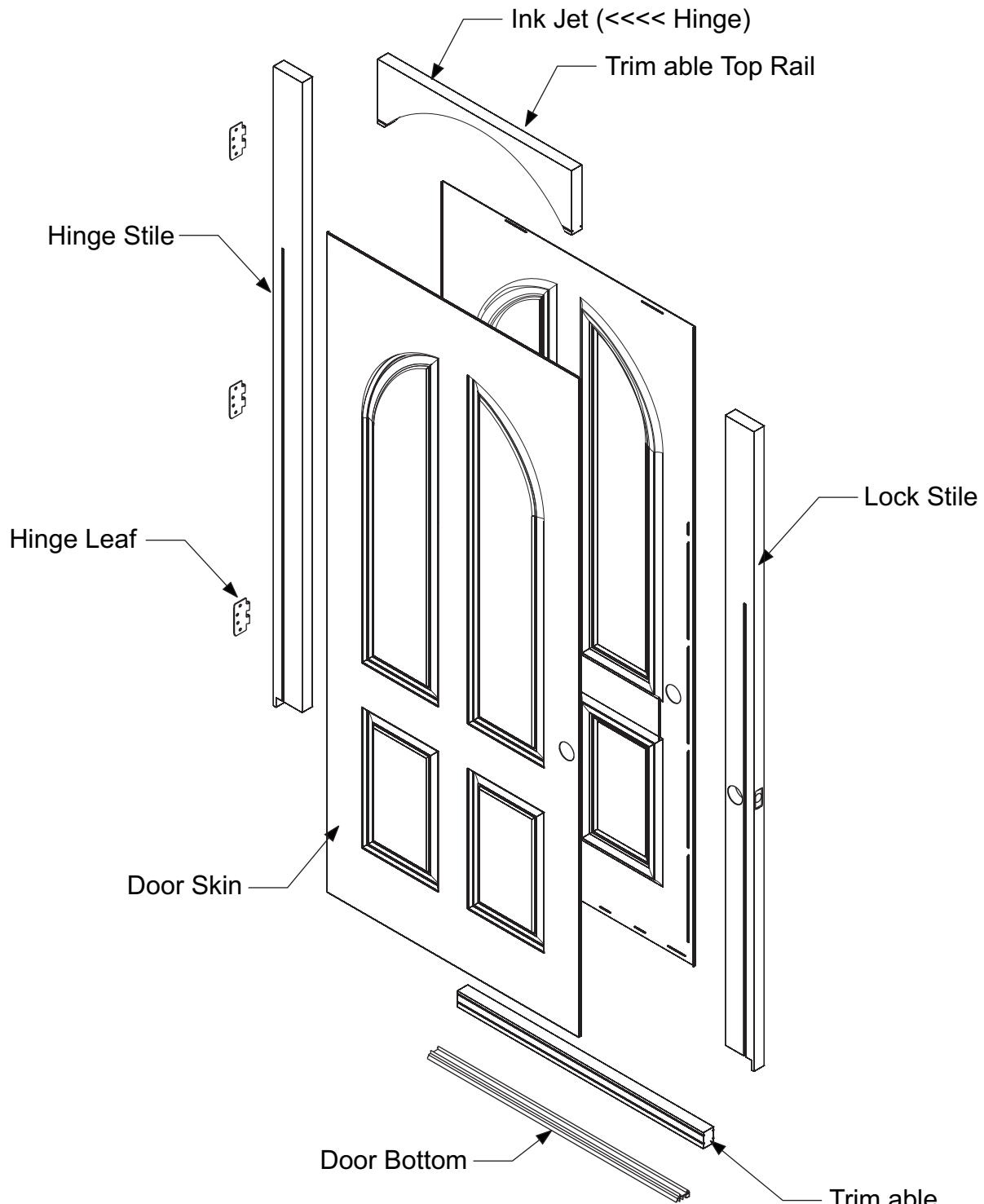

Classic-Craft Arched / Radius (Radius Top Shown)

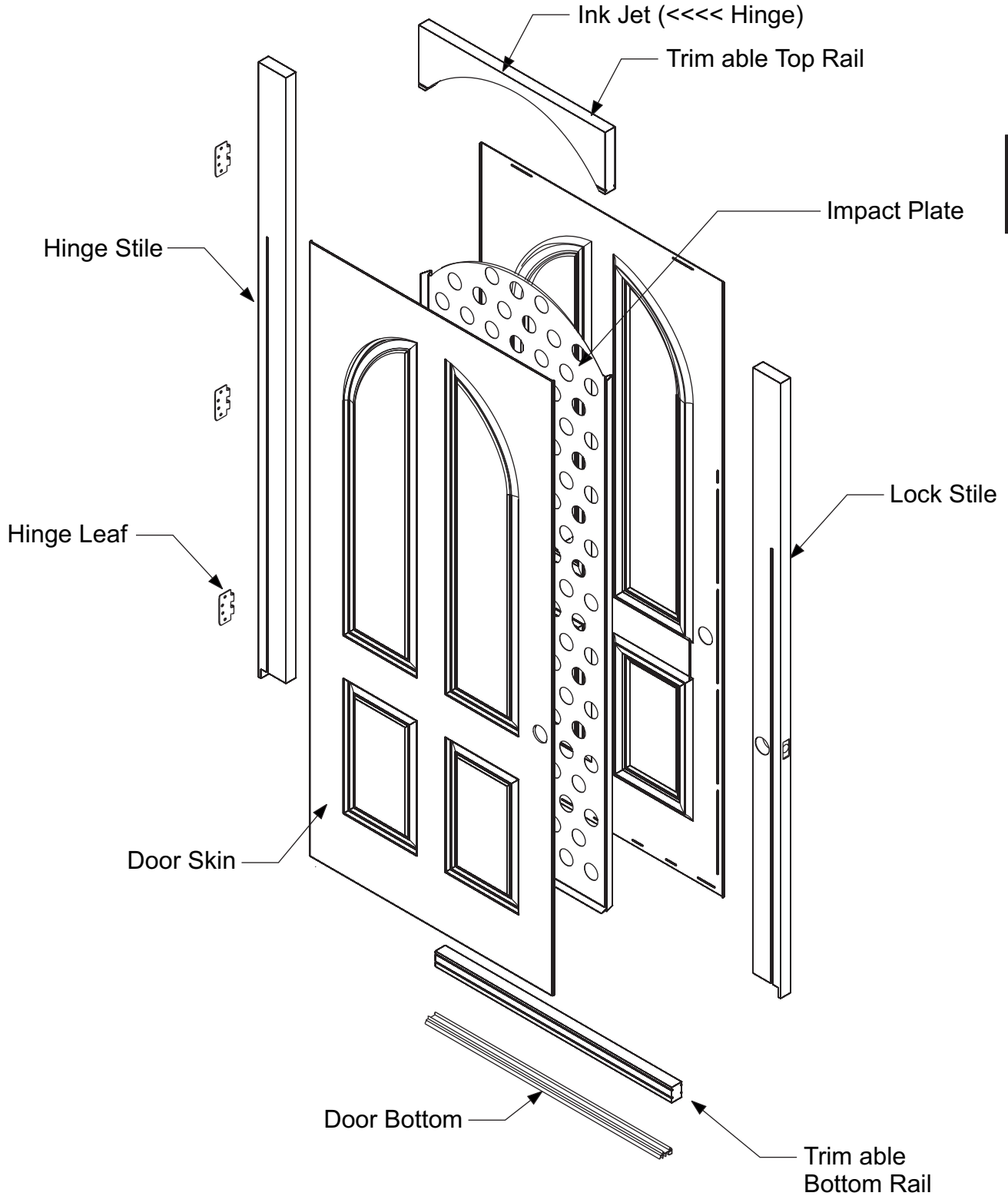

Classic-Craft Arched / Radius Impact

DOOR
PREP

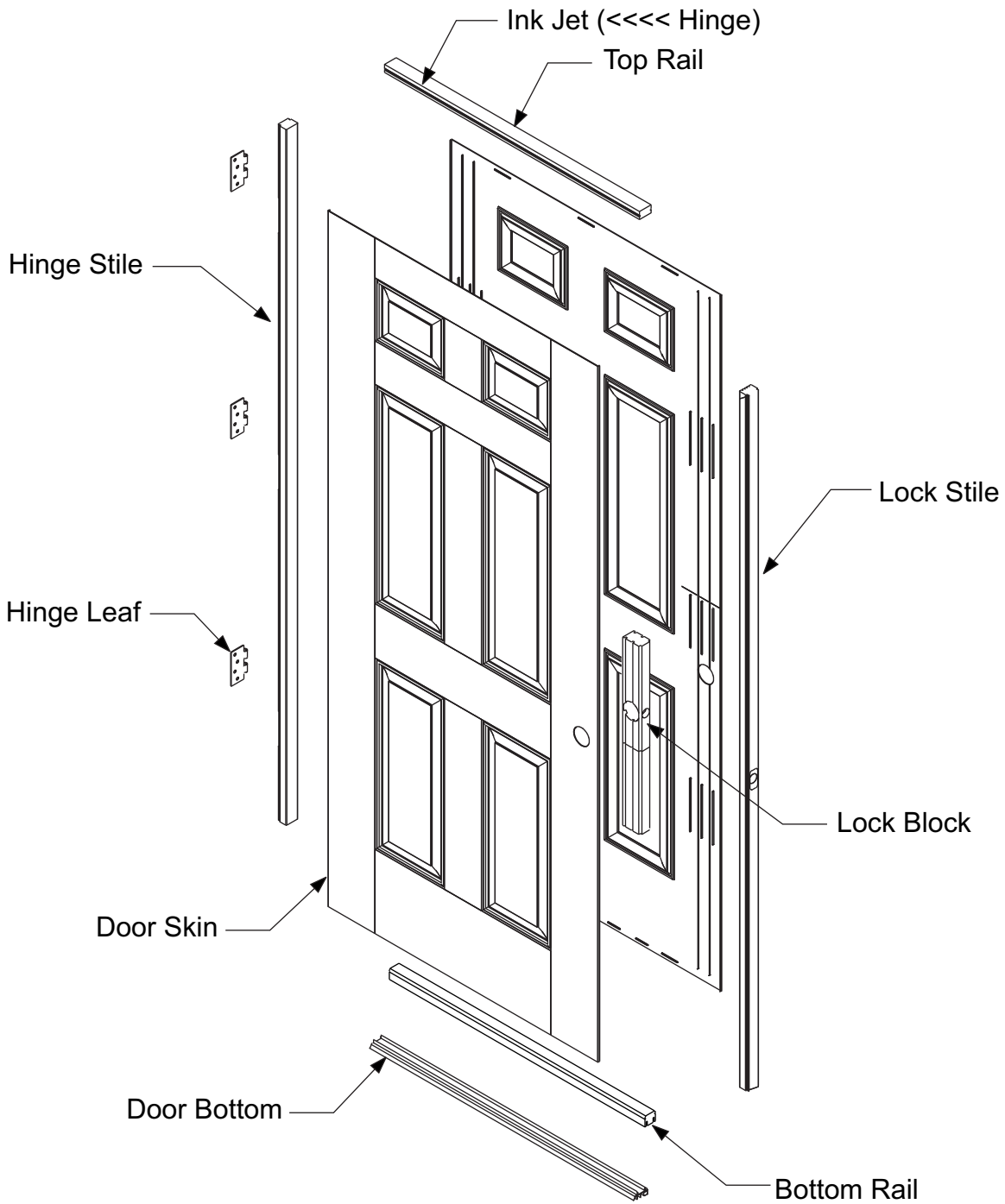

Fiber-Classic

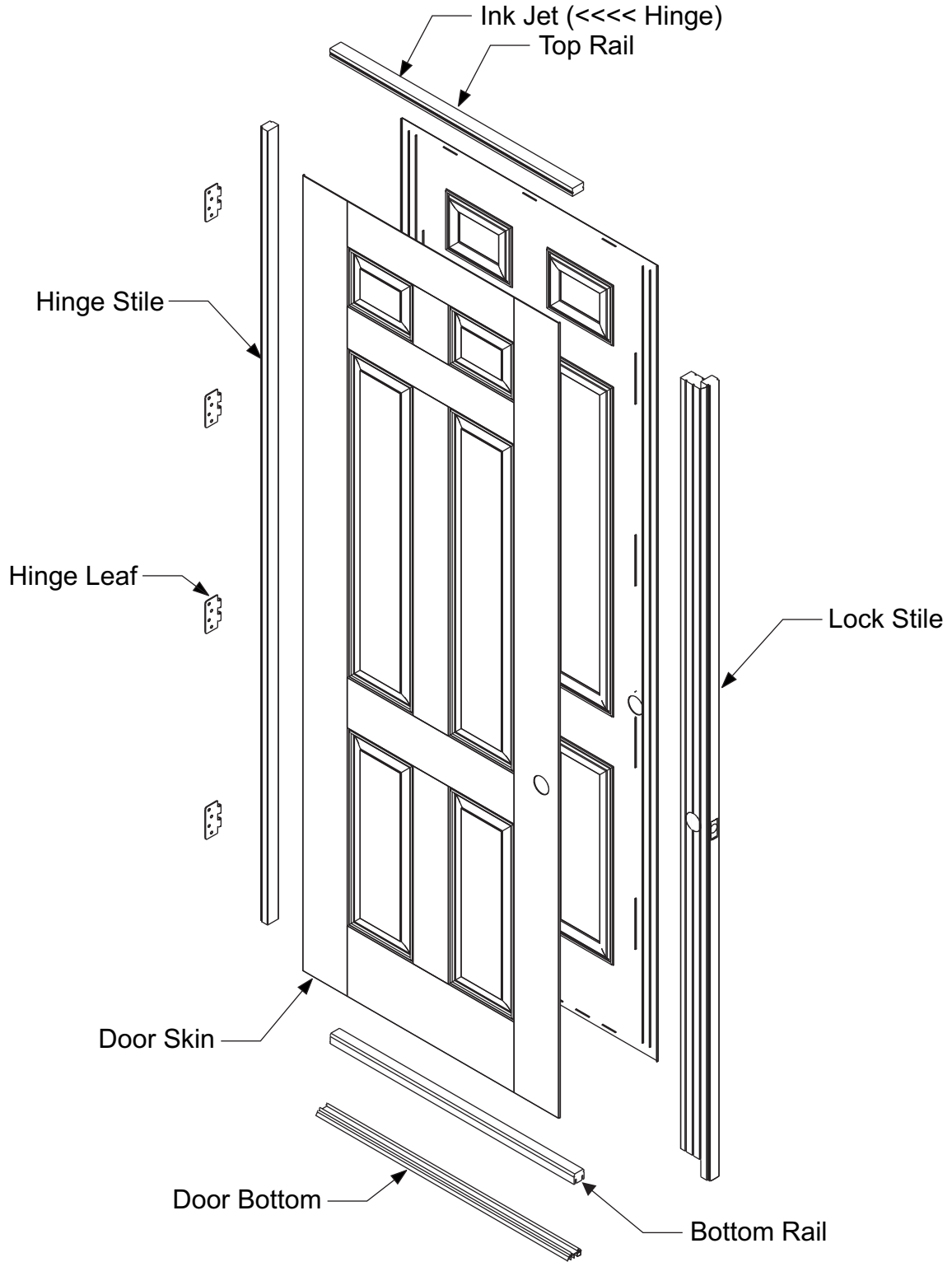

DOOR
PREP

8/0 Fiber-Classic

DOOR
PREP

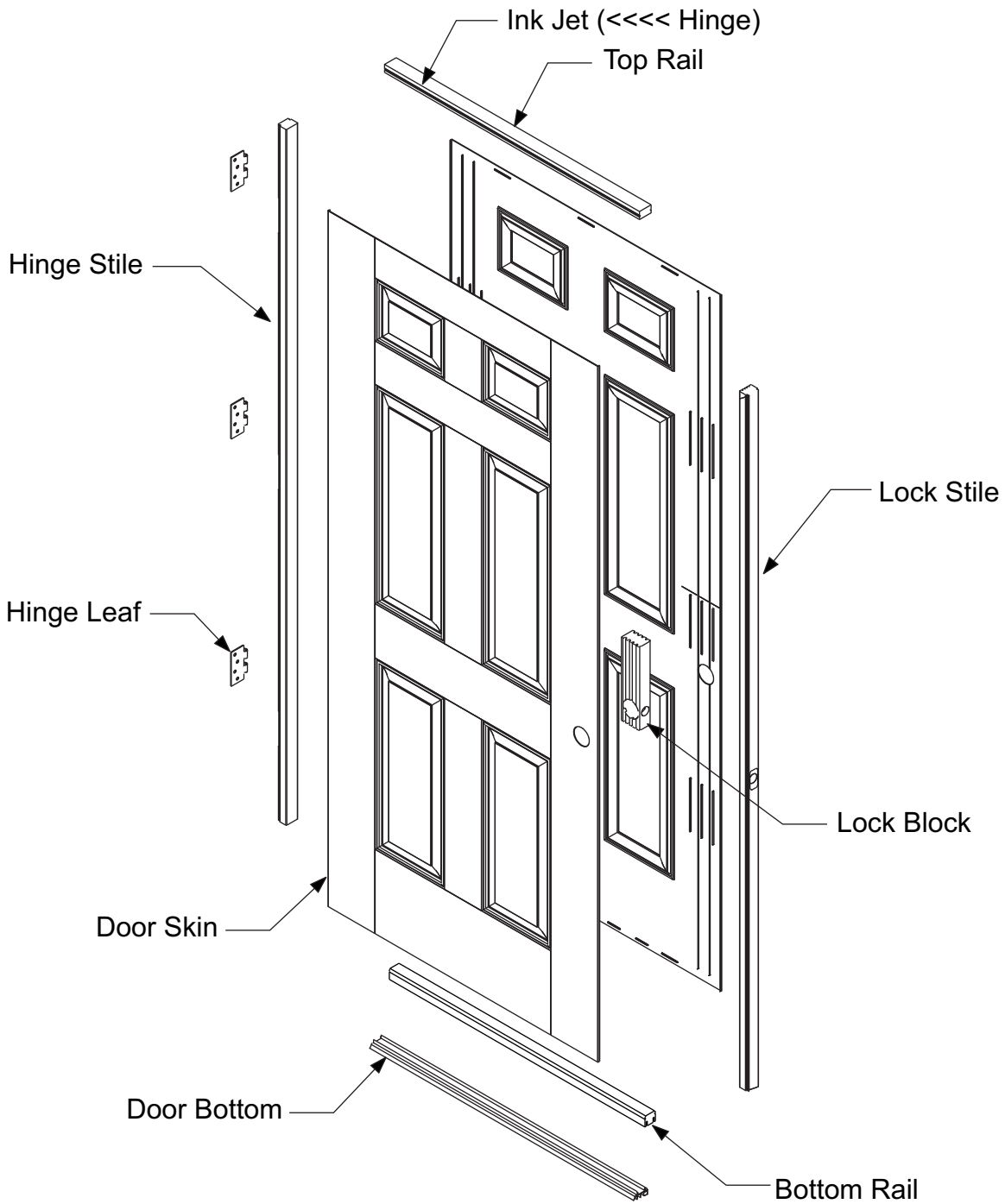

Smooth-Star

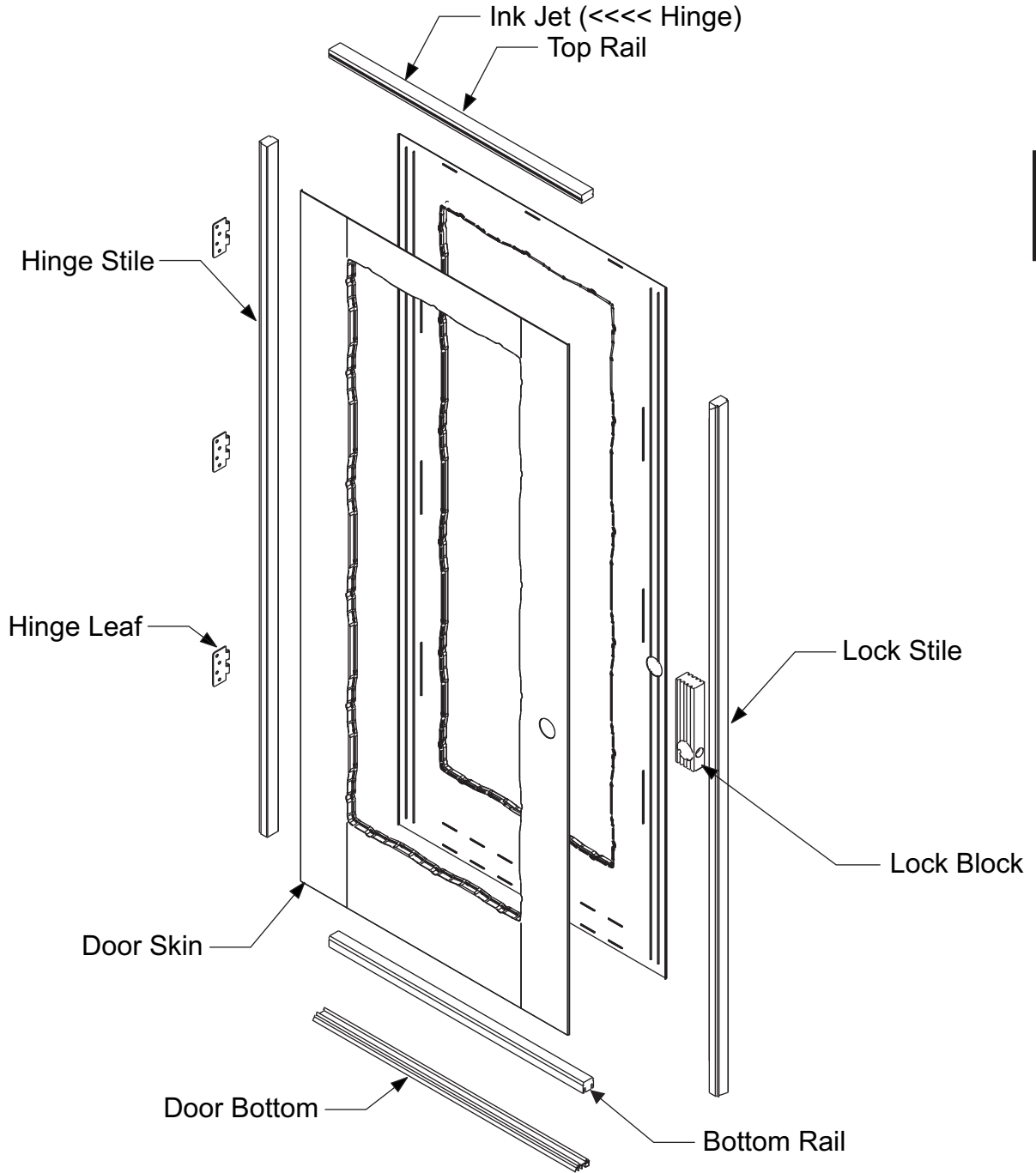

DOOR
PREP

Smooth-Star
(Molded Open - Ready to Receive Doorlite)

DOOR
PREP

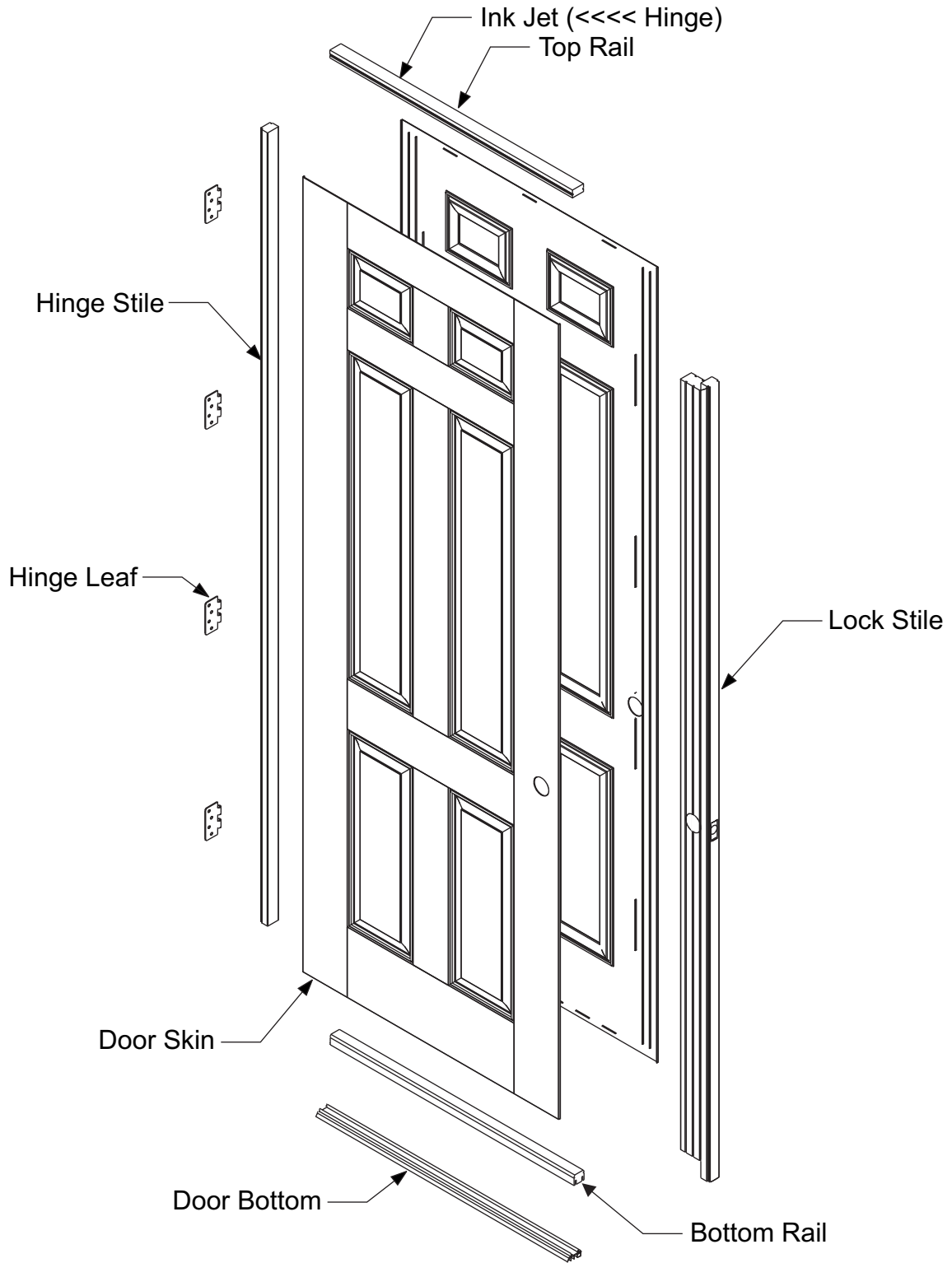

8/0 Smooth-Star

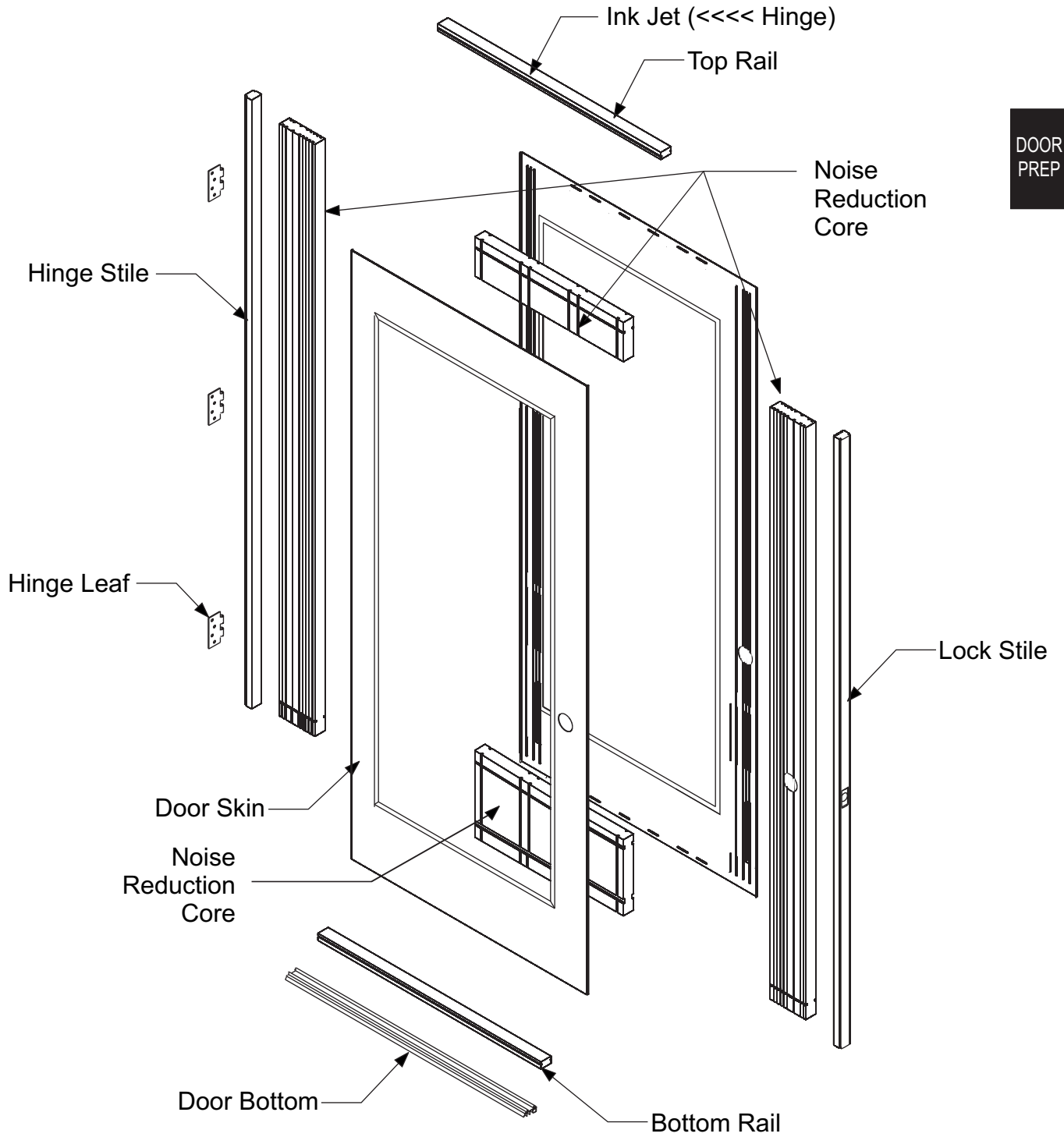

Smooth-Star Noise Reduction
(Factory Cutout Only)

DOOR
PREP

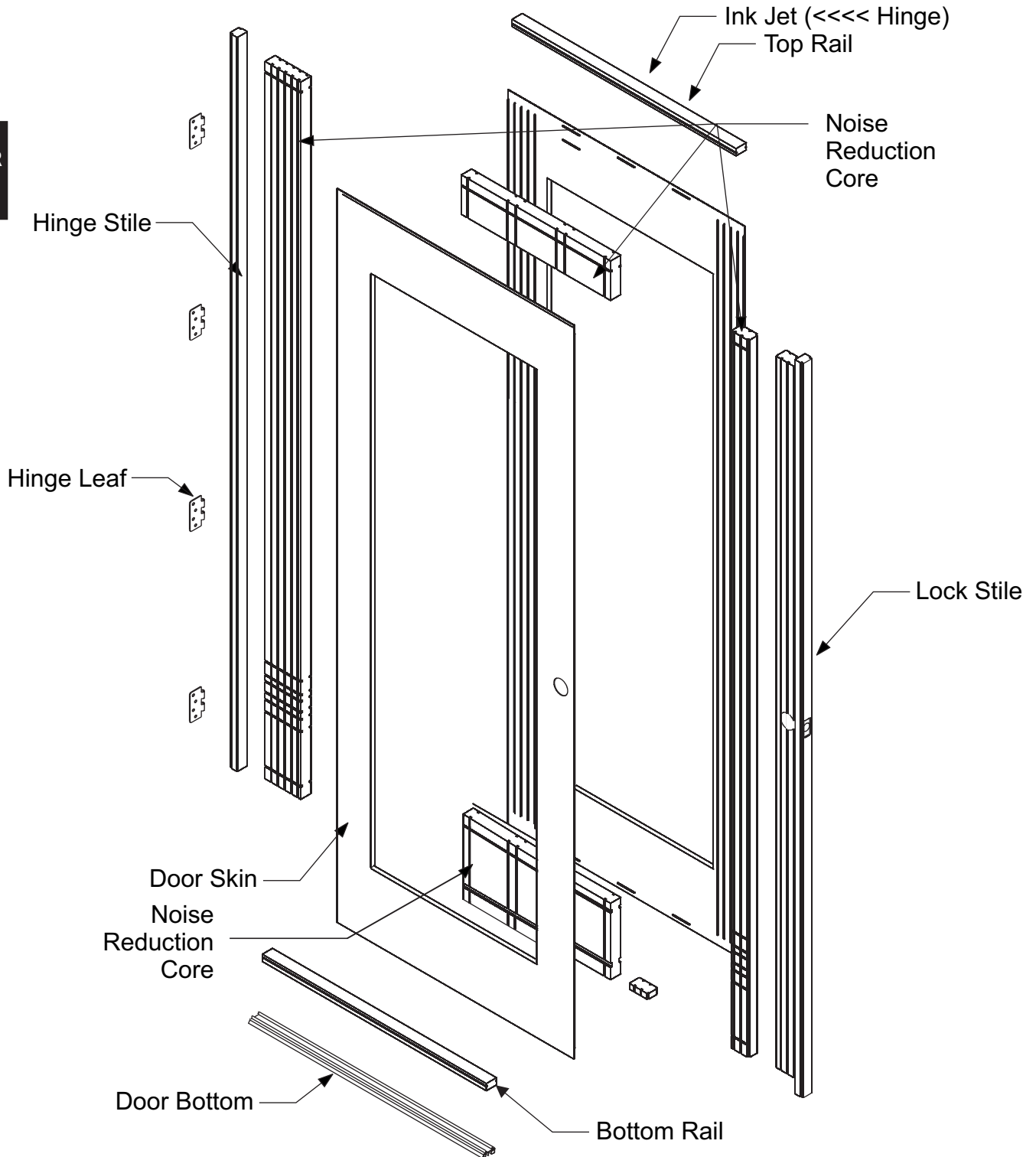

8/0 Smooth-Star Noise Reduction (Factory Cutout Only)

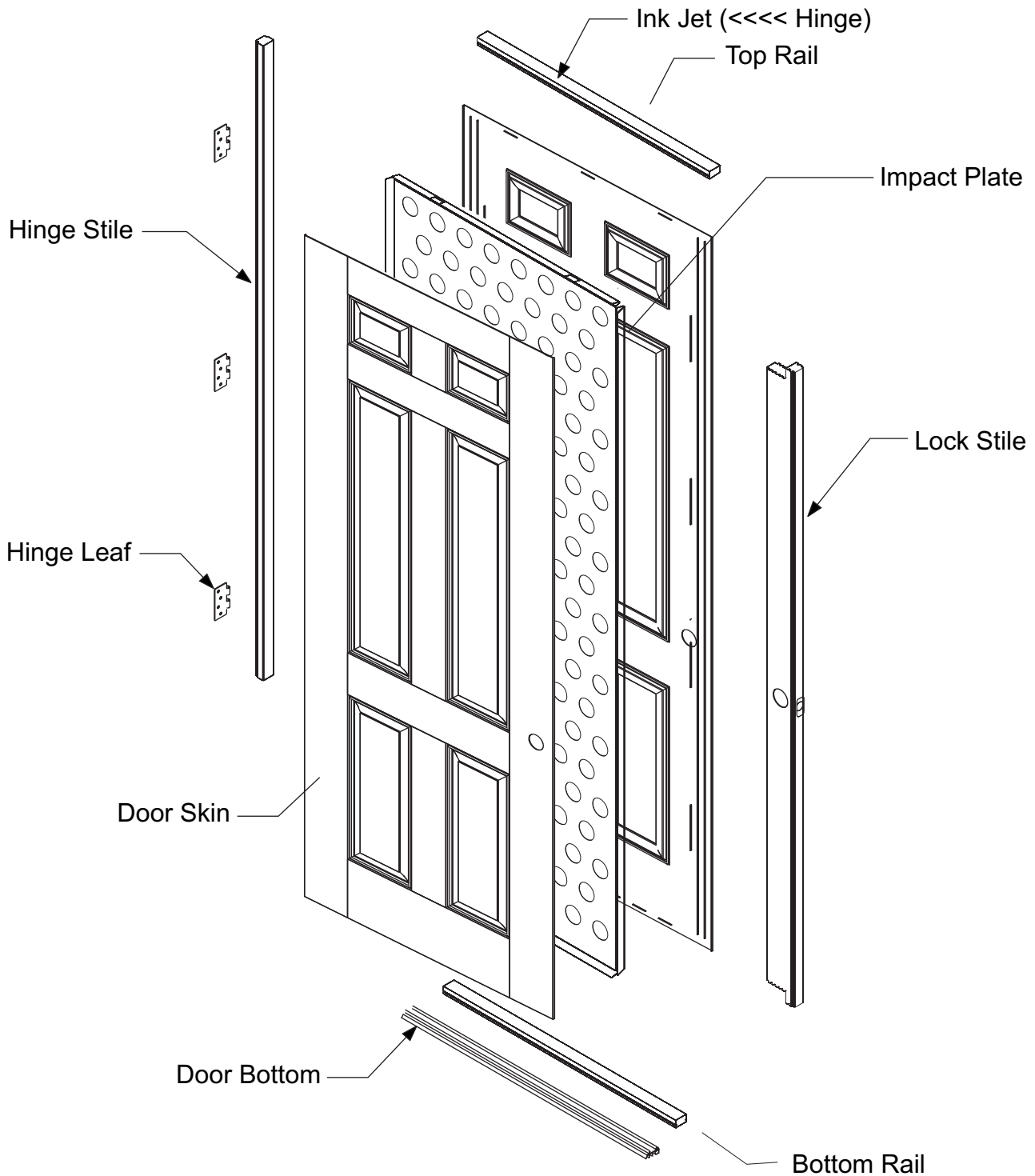

Fiber-Classic/Smooth-Star Impact

Exploded View and Part Identification

DOOR
PREP

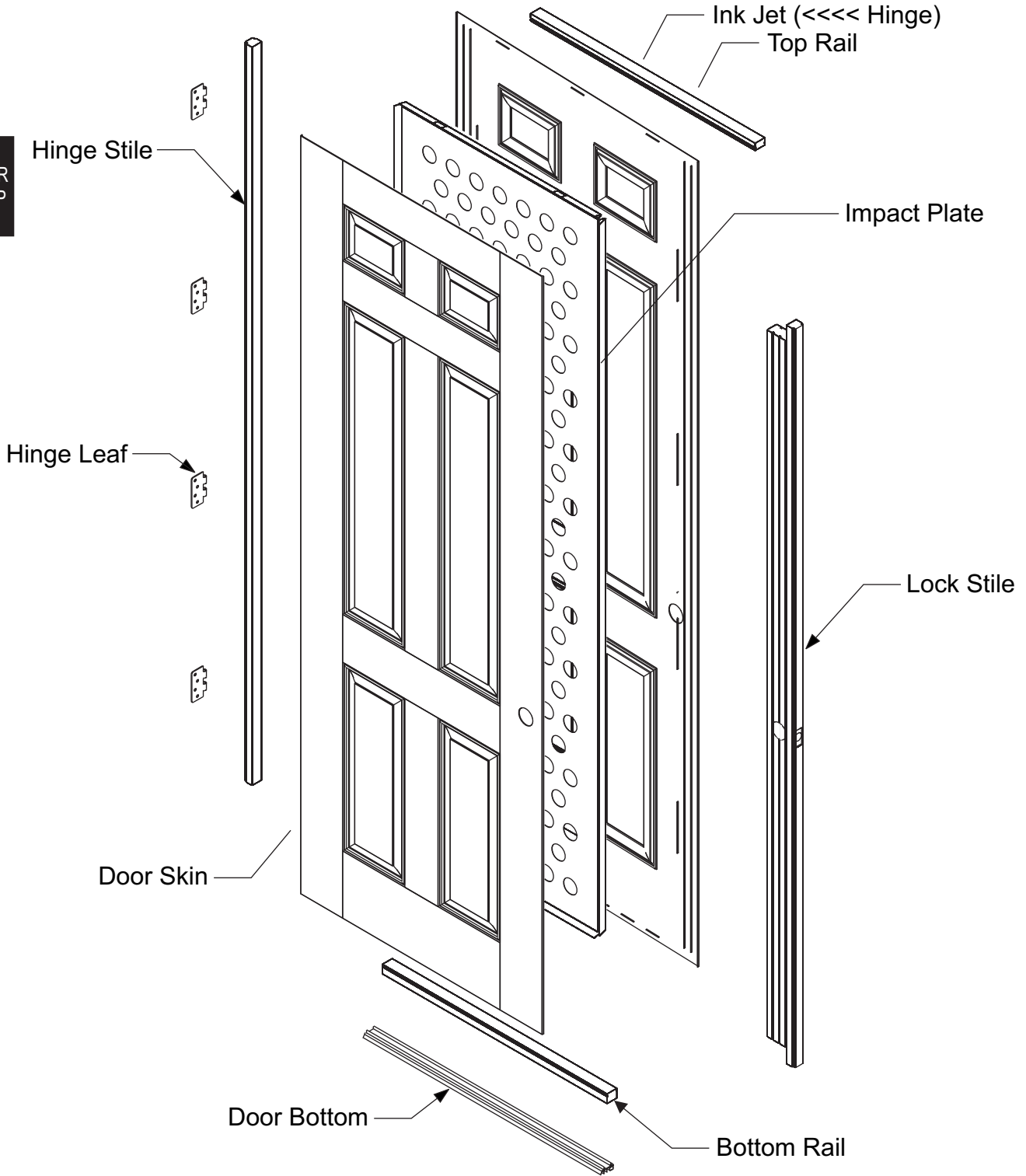

8/0 Fiber-Classic/Smooth-Star Impact

DOOR
PREP

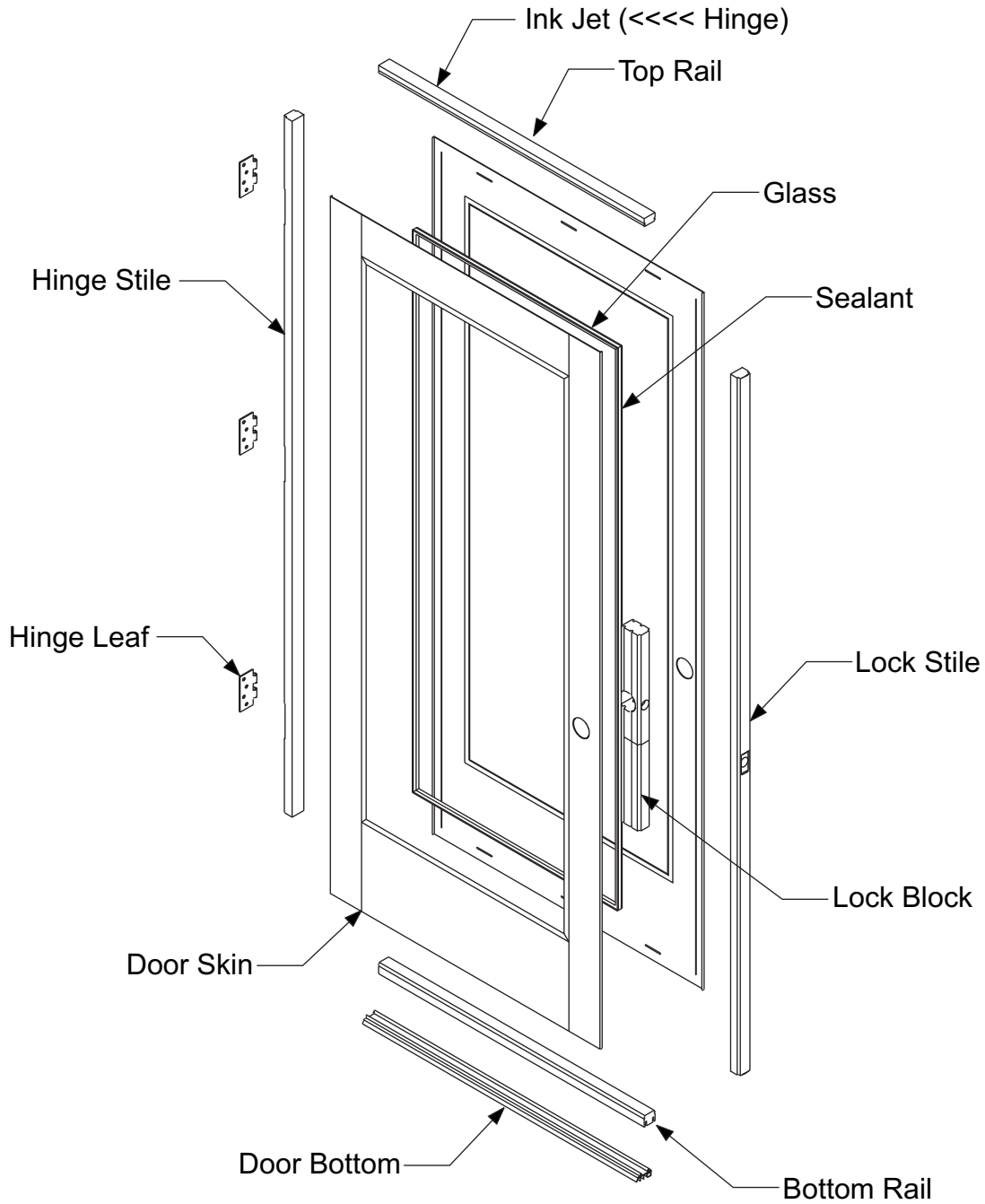

**Flush-Glazed
Fiber-Classic/Smooth-Star**

DOOR
PREP

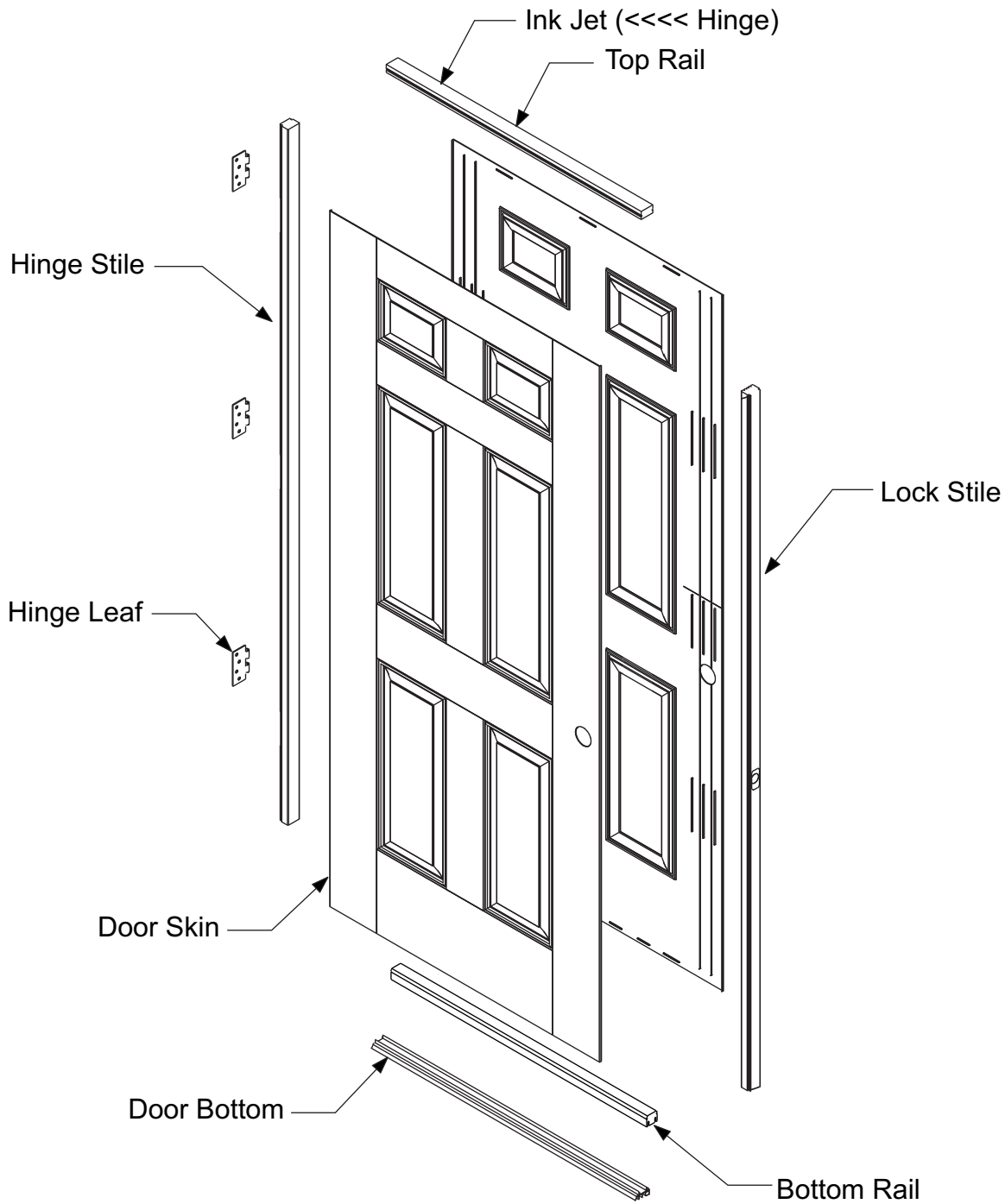

20-Minute Positive Pressure Fiber-Classic & Smooth-Star Fire Door

DOOR
PREP

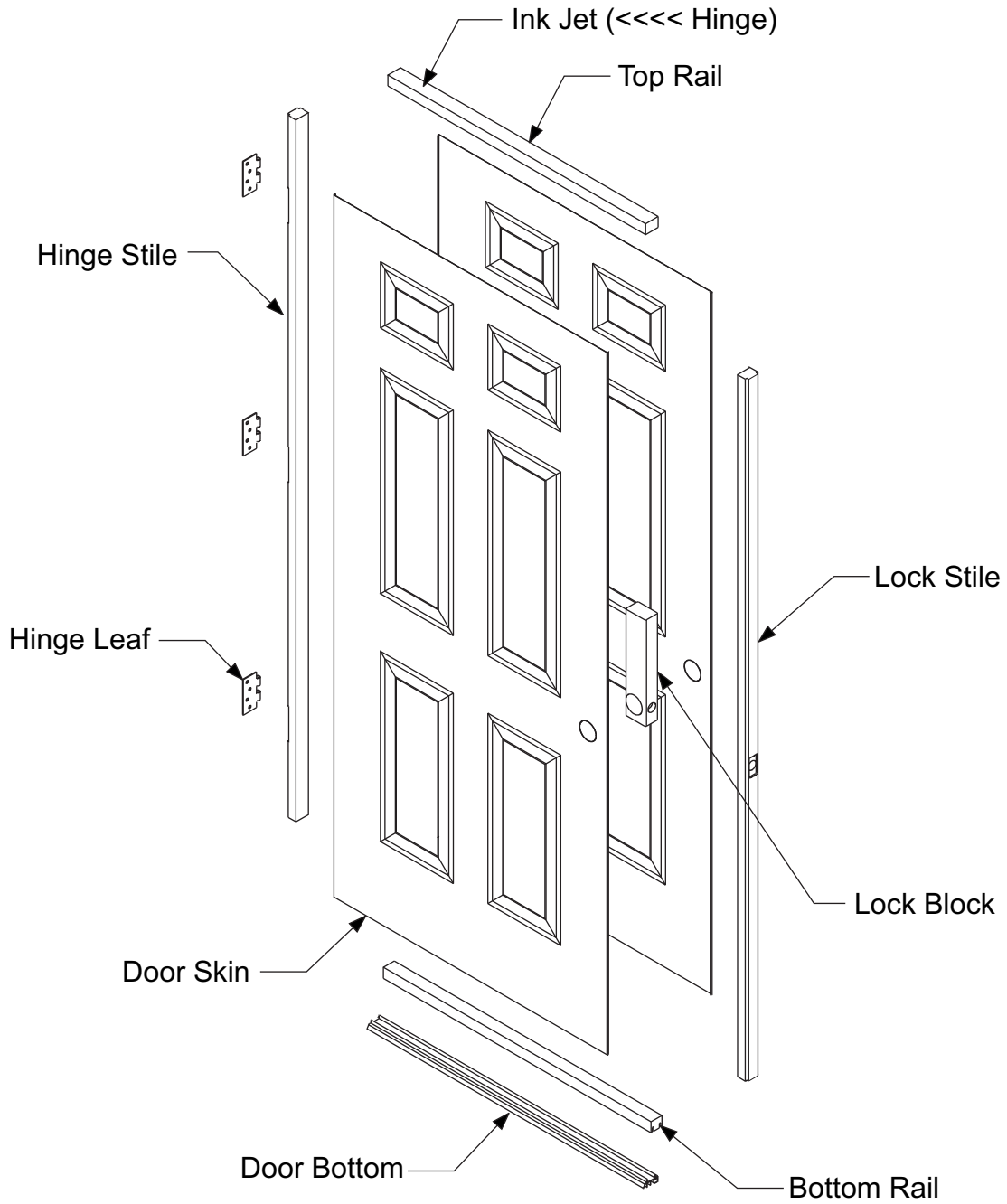

Profiles Steel

DOOR
PREP

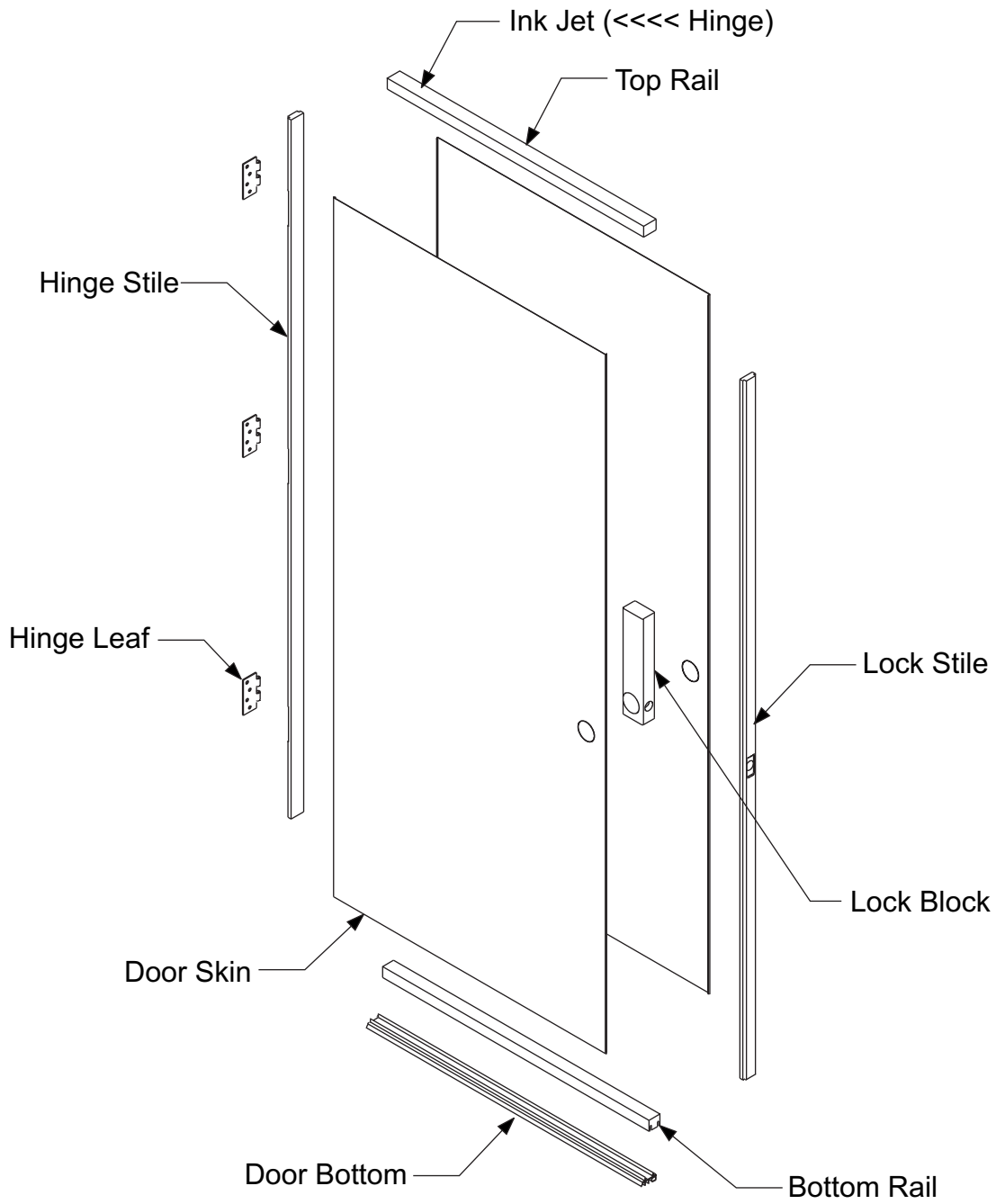

Traditions Steel

DOOR
PREP

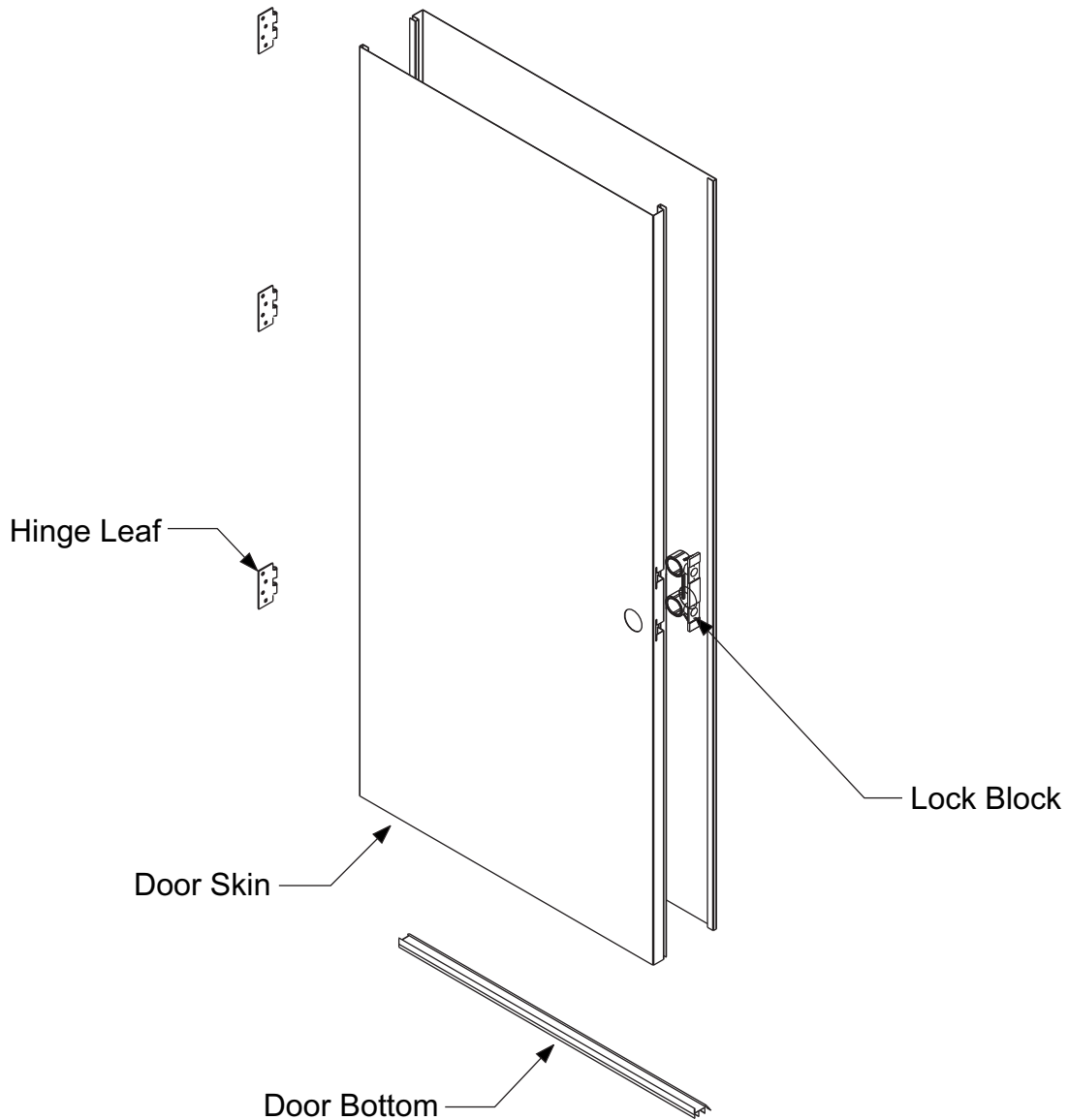

**90-Minute Positive Pressure
Steel Edge Fire Door**

Stile, Rail and Reinforcement Block Sizes and Locations

DOOR
PREP

CLASSIC-CRAFT

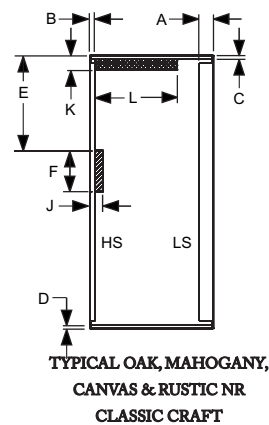
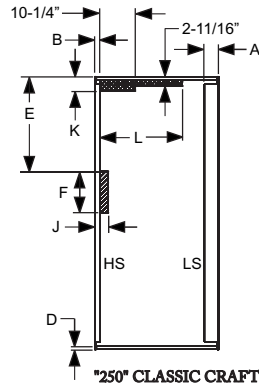
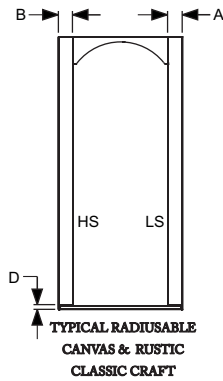

FIBER-CLASSIC

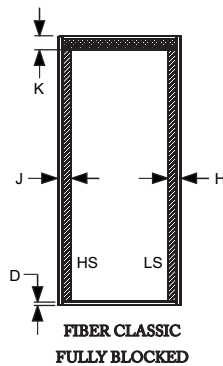
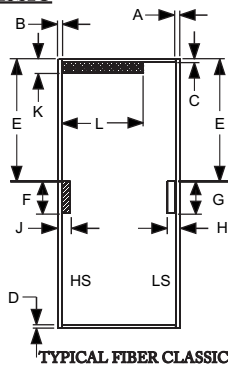

Note:
Shaded blocks are
extra-cost options.

- STANDARD BLOCKING
- PANIC PREP BLOCK
- CLOSURE BLOCK

NOTE:
FULLY BLOCKED NOT
AVAILABLE IN FLUSH GLAZED

HS = Hinge Stile
LS = Lock Stile

SMOOTH-STAR

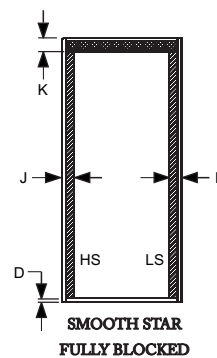
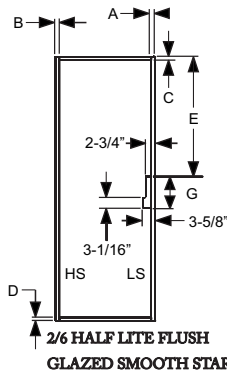
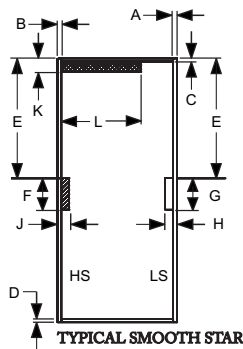

NOTE:
FULLY BLOCKED NOT
AVAILABLE IN FLUSH GLAZED

STEEL

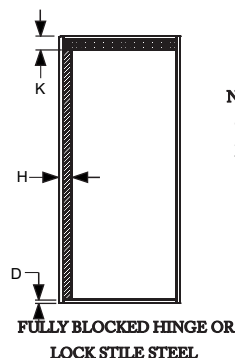
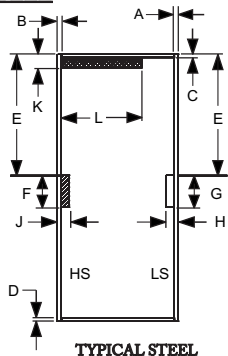

NOTE:
ONLY ONE STILE CAN BE FULLY BLOCKED, EITHER
LOCK OR HINGE.



Note:
See Chart for
Dimensions
on Next Page

Stile, Rail and Reinforcement Block Sizes and Locations

	A Lock Stile Width	B Hinge Stile Width	C Top Rail Height	D Bottom Rail Height	E Lock & Panic Block Location	F Panic Block Length	G Lock Block Length	H Lock Block Width = Lock Stile Width + Lock Block Width	J Panic Block Width = Hinge Stile + Panic Block Width	K Closure Block Height = Top Rail Height + Closure Height	L Closure Block Size Width
Classic-Craft											
6/8 Standard Doors											
6/8 Rustic & Canvas Non-Radius											
"040" & "200" Doors											
"250" Door											
8/0 Standard Doors											
8/0 Rustic Non-Radius											
"750", 6/8 & 8/0 American Style & Canvas 1-Panel Plank	4-1/8"			1-15/16"	27-5/8"	24"			4-1/8"	4-1/8"	24"
Arched & Radius Rustic & Canvas 6/8		1-1/2"	1-15/16"		43-5/8"						
Arched & Radius Rustic 8/0 Doors		4-1/8"	1-1/2" +		Not Available					Not Available	
6/8 Fire Doors		1-1/2"	1-15/16"								
8/0 Fire Doors		1-1/2"	1-15/16"								
Fiber-Classic											
6/8 Embossed Doors											
6/8 Designline Doors											
6/8 Flush Glazed 1/2 Lite Doors											
6/8 Flush Glazed full Lite Doors	1-3/16"										
6/8 Molded Open											
7/0 Embossed Doors											
7/0 Flush Doors											
8/0 Standard Doors											
8/0 Flush Glazed Doors		1-3/16"	15/16"	15/16"	36"	12-1/2"			3-9/16"	4"	24"
8/0 Molded Open Doors					Not Available						
6/8 Fire Doors					Not Available						
7/0 Fire Doors					36"						
8/0 Fire Doors					Not Available						
4-1/8"					Not Available						
Smooth-Star											
6/8 Standard Doors											
6/8 Flush Glazed 1/2 Lite Doors											
2/6 Half Lite Flush Glazed											
3/4 & Full Lite Lite Flush Glazed											
8/0 Doors	4"										
6/8 Molded Open	1 3/16"	1-3/16"	15/16"	15/16"	42"	12-1/2"			3-9/16"	4"	24"
8/0 Flush Glazed Doors					Not Available						
6/8 Fire Doors					Not Required Wide Lock Stile See Column "A"						
8/0 Fire Doors					Not Required Wide Lock Stile See Column "A"						
Steel											
Profiles & Traditions Steel											
6/8 Doors											
7/0 Doors											
8/0 Traditions Doors	1 1/4"	1 1/4"	7/8"	7/8"	35 3/4"	12 1/2"			3 7/8"	3 7/8"	24"
Patio Doors					39 3/8"						
					42"						
					35 3/4"						
Not Available HPC Filled											

DOOR
PREP

90 Minute Positive Pressure Steel Fire Door Reinforcement Sizes & Locations

DOOR
PREP

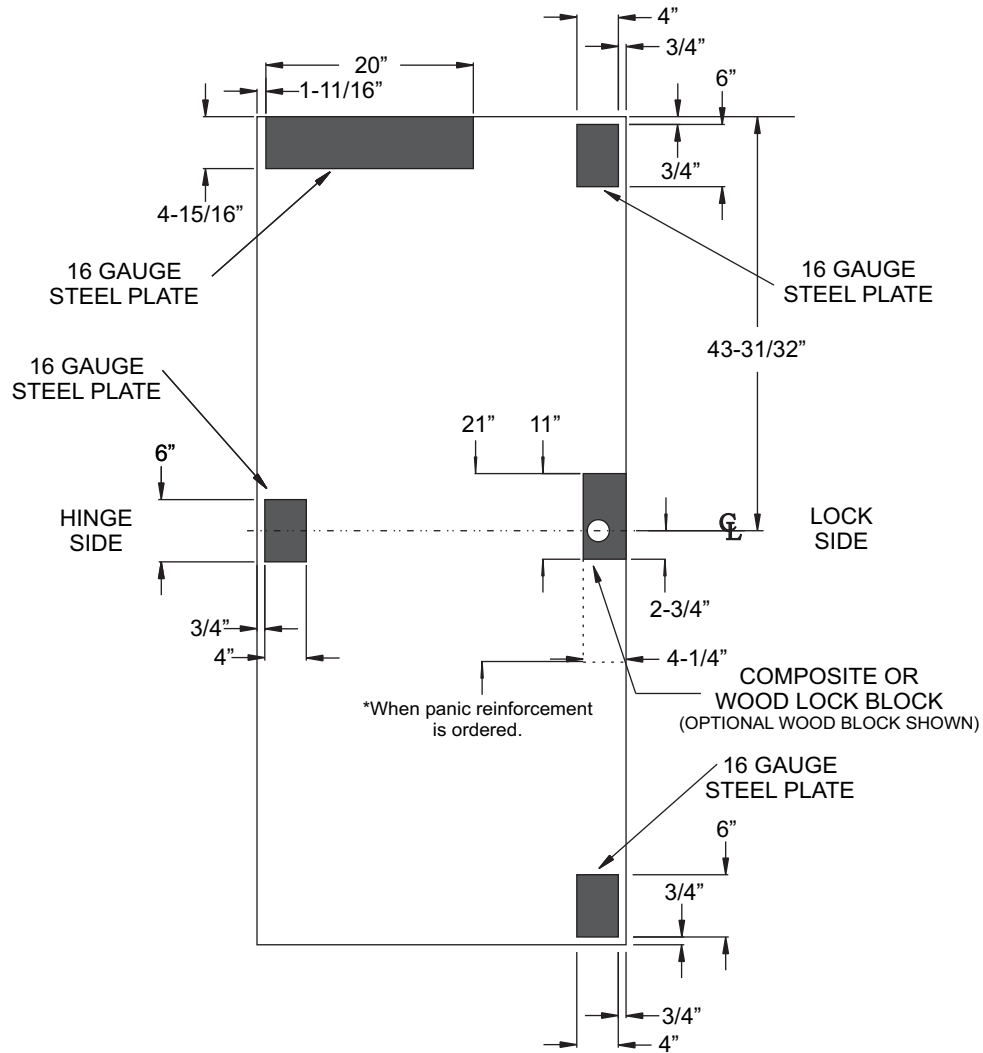

Shaded areas are extra-cost options.

Maximum height and width trims for standard doors.

MAXIMUM EDGE AND END TRIMS

Door Slab	A Top Rail	B Bottom Rail	C Hinge Stile	D Lock Stile
Classic-Craft	1-1/4"	1-1/4"	1/8"*	1/8"*
Fiber-Classic	1/4"	1/4"	1/8"	1/8"
Smooth-Star	1/4"	1/4"	1/8"	1/8"
Steel Doors	1/4"	1/4"	1/16"	1/16"

* Inspect corners to verify available oak thickness before trimming.

NOTES:

1. 90-minute positive pressure fire doors cannot be width-trimmed.
2. Fiber-Classic and Smooth Star 20-minute positive pressure fire doors can only be trimmed from the bottom of the door. This machining can only be completed by certified door machine shops.
3. Trimming the bottom rail may prevent the kerf door bottom from fitting properly. A replacement staple-on door bottom may need to be used.
4. For resizing beyond maximum trimming, see Shop 3 - Door Slab Resizing.

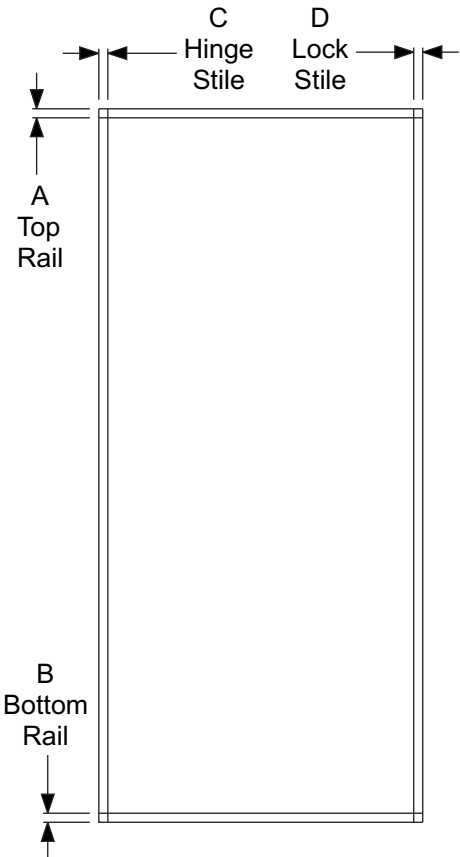
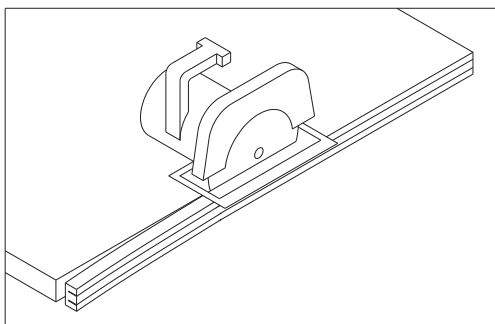
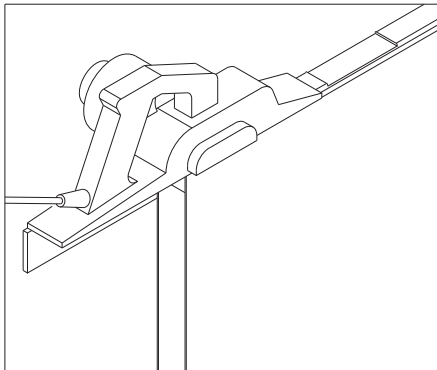

Trim Slab to Width

Set planer cutting depth.

Plane edges of slab.

Sand smooth if required.

Paint with primer if required to match original finish.

Trim Slab to Height

Measure and mark door slab.

Cut along line with saw, using carbide-tipped blade.

Touch up edges with a rasp or sandpaper.

Door Slab Resizing

Door Slab Resizing Beyond Maximum Trimming Limits



CAUTION:

Does not include 90 or 20-minute fire doors. See 90 minute positive pressure fire door resizing.

DOOR
PREP

Height Resizing

Note:

There is no limitations on the size of the cut-down as long as the style is aesthetically acceptable and the procedure for re-railing is followed as specified here.

Any height resizing beyond maximum trim requires rail replacement.

Width Resizing

Doors cannot be edge-trimmed beyond the limits listed in SHOP 3 - Door Slab Trimming

Saw Slab to Length

Measure and mark door slab.

Cut along line with saw, using carbide-tipped blade.

Touch up edges with rasp or sandpaper.

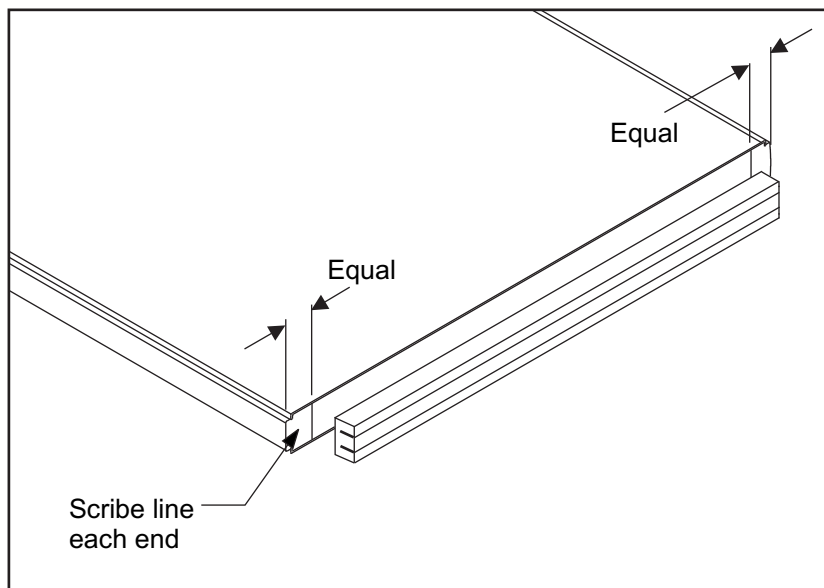
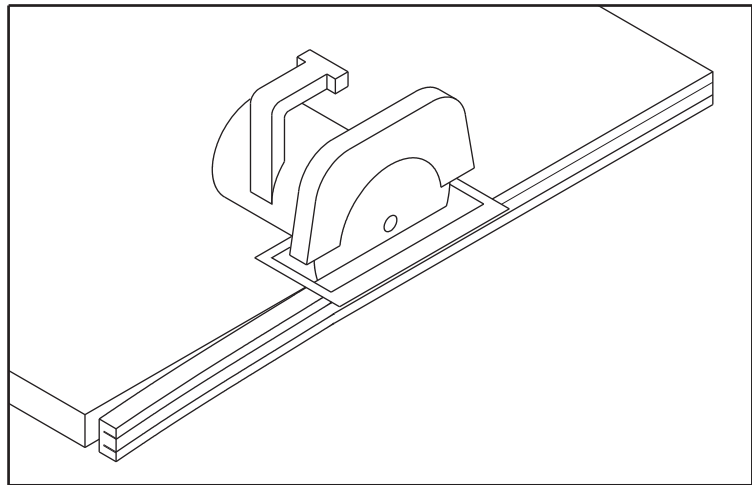

Mark for New Rail Pocket

Use new rail as a pattern.

Center rail against cut end of door slab.

Scribe at rail ends to mark limits of cut for rail pocket.

Set Router Cutter Depth

Use new rail to set router bit depth.

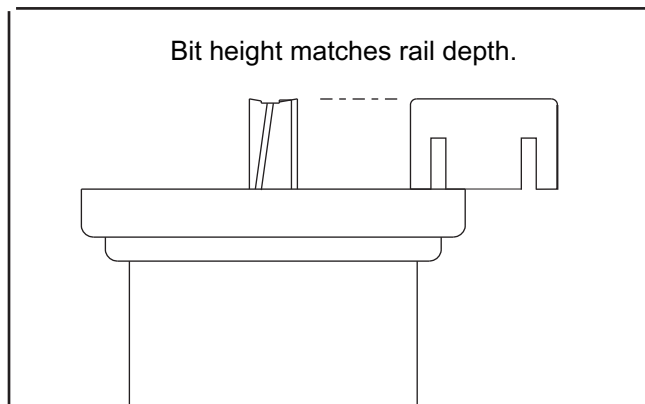

DOOR
PREP

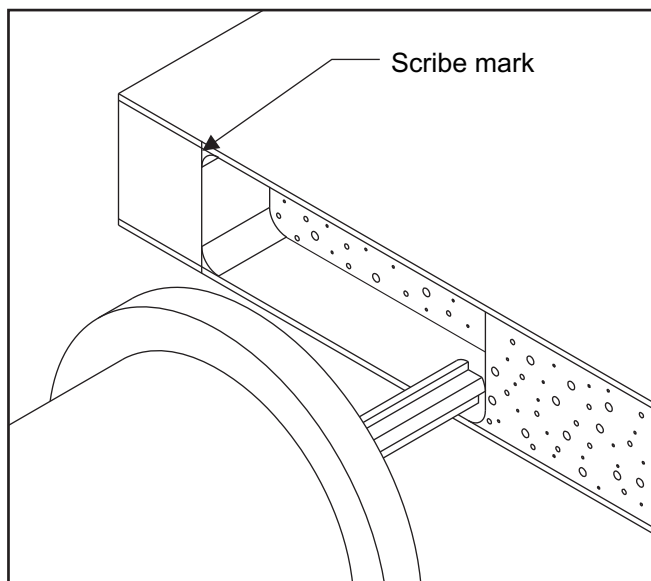

Cut New Rail Pocket

Plunge-rout entire recess to full depth.

Cut to scribe marks at ends.

Cut flush to inside skin faces.

Clean Up New Rail Pocket and Test-Fit

Clean up corners with a chisel.

Scrape skin faces clean to ensure a good adhesive bond.

Test-fit rail in pocket.

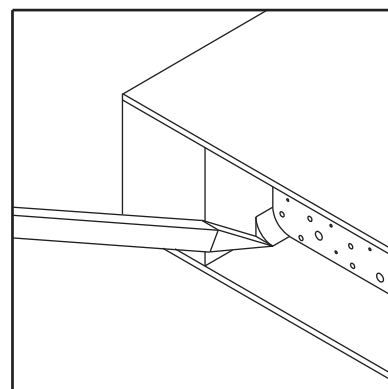

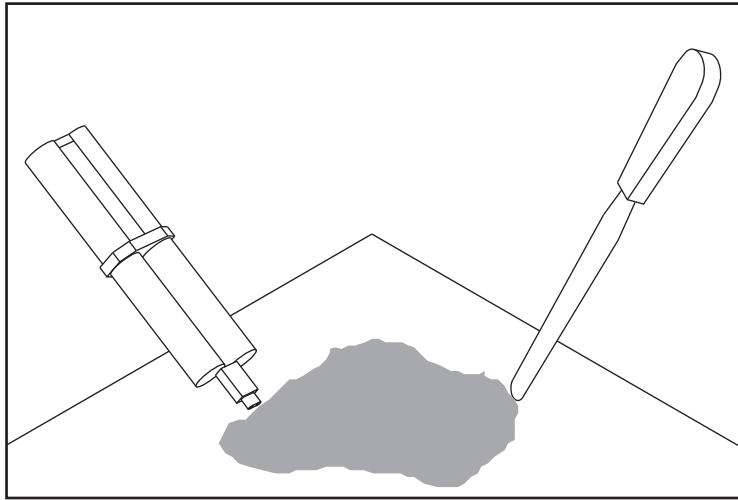

Mix Adhesive

Use a fast-setting epoxy.

Mix thoroughly before applying to door skins.

Apply Adhesive

Fully coat inside skin surfaces of rail pocket.

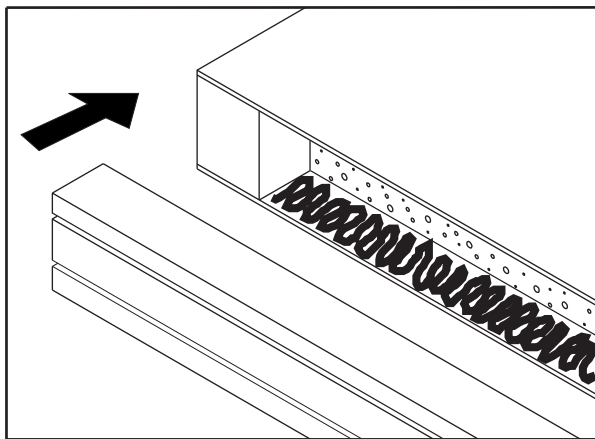
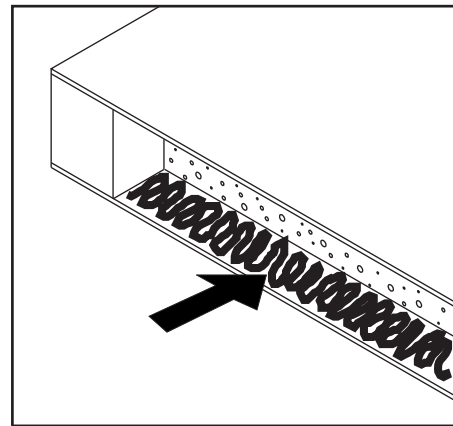

Insert Rail

Use plain, no-kerf rails at top of door.

At bottom end, place rail in pocket with kerfed edge facing out.

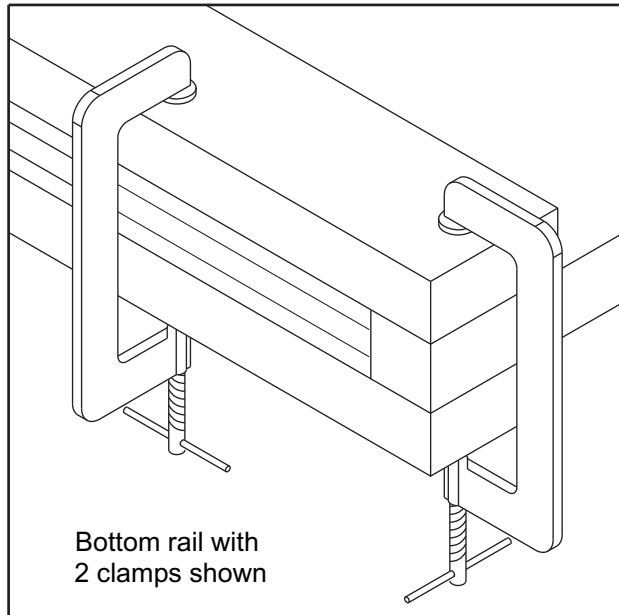

Clamp Assembly

Clamp to ensure uniform pressure.

Use pad boards to protect slab skins.

Allow to dry per adhesive instructions.

DOOR
PREP

For door bottom attachment, see SHOP 3 - Door Bottom Selection & Installation

90-Minute Fire Door Slab Resizing



CAUTION:

Only shops licensed by Warnock-Hersey as fire door machiners may perform this resizing procedure. These instructions are for reference only. Please refer to the current Warnock-Hersey machining report for the currently approved procedure.

DOOR
PREP

Method of “Cutting Down” Steel Doors

NOTE: The maximum total cut down is 4". If the door is to be used in a steel frame, the bottom of the door should be cut off, as it is recommended that steel frames be cut down "from the bottom" when making special height openings. If used in a wood frame, the top of the door can be cut off; the head of the wood frame may be dropped down to fit by cutting down the tops of the side jambs.

Step #1: Cutting Bottom (or top) of Door

Cut bottom (or top) of door off to desired length using a saber saw. (See *Detail A*). Cut one side of door at a time. If saw blade is too long, break off blade so that length of blade does not project more than 1-1/2" on down stroke.

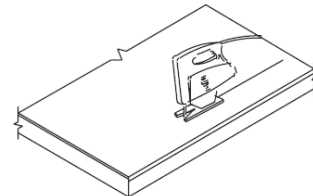

Detail A

Step #2: Clean Area for Installation of Channel*

Run an electric drill with 3/16" drill bit along bottom, (or top) of door to remove foam core about 1" deep. (See *Detail B*). Remove enough core to allow channel to insert between door skin and foam. Thoroughly clean door surfaces that will make contact with tape on channel. A file or sandpaper may be used to clean off foam.

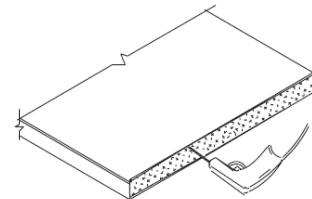

Detail B

NOTE: Foam tape may not stick if surface is not totally cleaned of insulating foam.

Step #3: Prepare Channel for Installation

Clean channel with paint thinner and allow to dry. Apply double face tape to both sides of channel. (See *Detail C*). Peel paper off tape. Channel is now ready for installation.

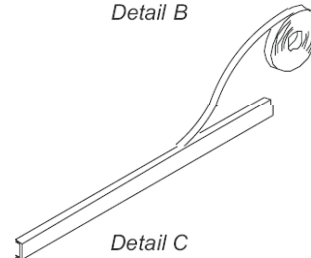

Detail C

Step #4: Install Channel

Start by inserting one end of the channel into the door, tight against either the lock or hinge side of the door. (See *Detail D*). Install remainder of channel. Make sure bottom channel is inserted flush and straight with the cut edge of the door.

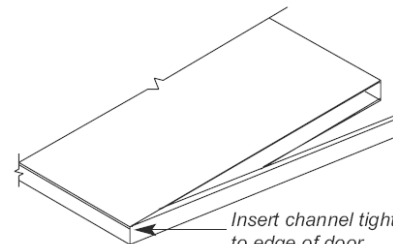

Detail D

Step #5: Apply Clamps

Place a wood strip (or equal) on each side of door. Hold strips 1/16" from edge of door. Apply clamps. (See *Detail E*). Clamps may be removed after a few minutes.

NOTE: Clamp pressure to be firm, not excessive.

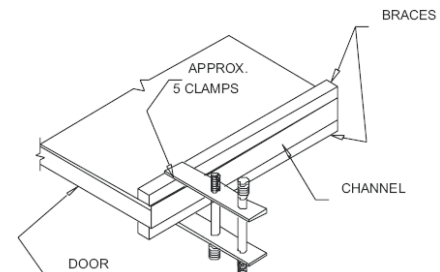

Detail E

* Top and bottom channels are found in the Components(CPL) section of the Taylor Door Entry Systems Price Manual.

Stile Chips

Fill Chips and Sand Smooth

Fill minor cosmetic damage to wood stiles with a hardening type wood putty.

File and sand smooth.

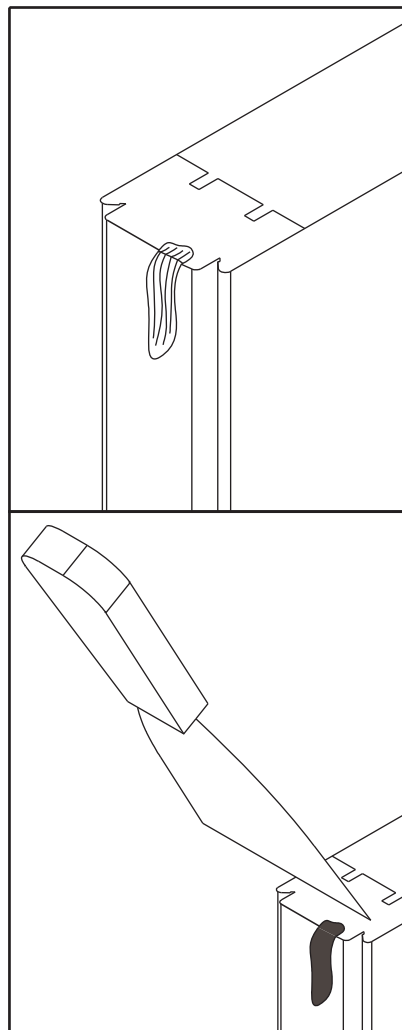

DOOR
PREP

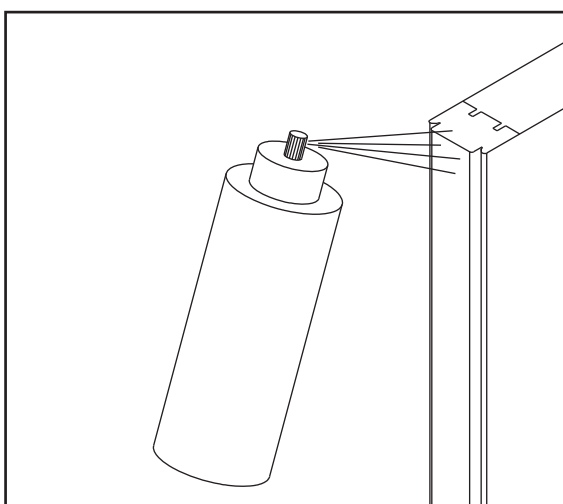

Reprime Area Using Touch-up Paint

Steel Door Dent Repair

Clean and Roughen Surface

Clean surface surrounding dent.

Roughen using 100 grit sandpaper.

If possible, do not sand through the existing factory-applied primer.

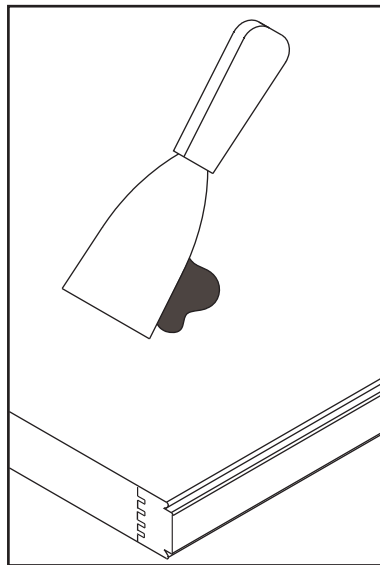
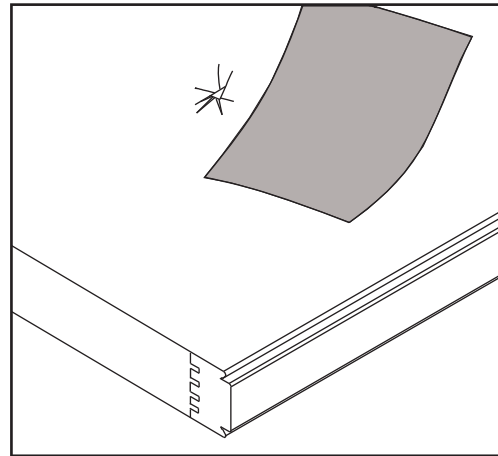

Fill Dent

Fill dent using Therma-Tru Dent Repair Kit, (Part Number: MS00DRK), or an automotive body-filler compound.

Smooth using a wide blade putty knife.

Overfill to account for shrinkage and sanding.

Sand Dent Repair

Sand repair, using a large sanding block or orbital power sander, with 220 grit sandpaper.

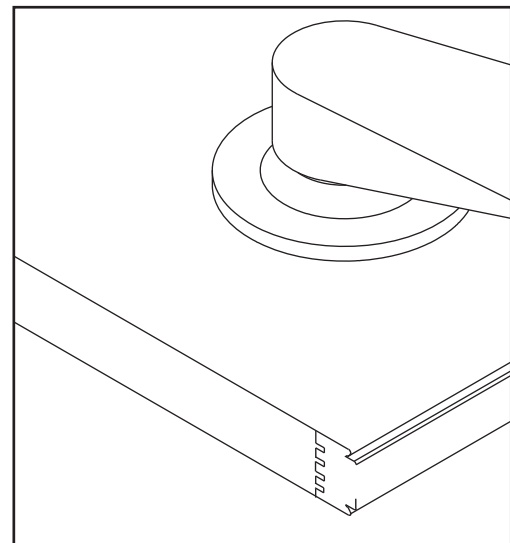

Steel Door Dent Repair - Cont.
Reprime Repair Area(s)

If bare metal was exposed, paint entire repair area with a primer containing rust inhibitors.

Reprime repaired area using Therma-Tru touch-up primer. If a rust inhibiting primer was used, let dry thoroughly before applying Therma-Tru touch-up primer.

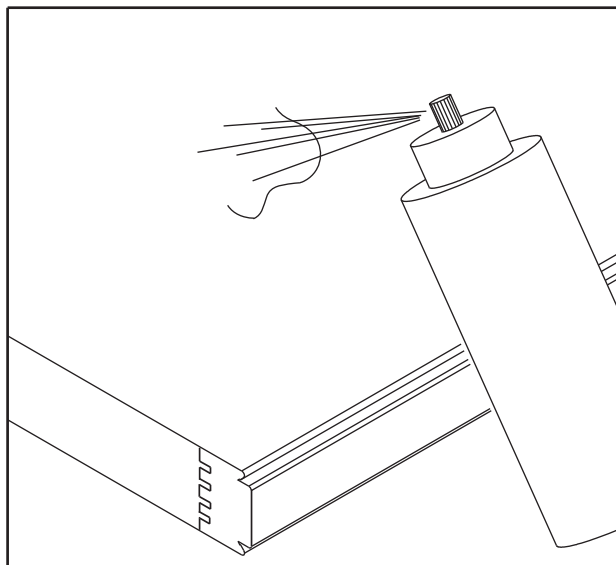

DOOR
PREP

THERMA-TRU TOUCH-UP PRIMERS

Description	Part Number
Classic-Craft and Fiber-Classic Primer for Buff skins	MSCCAB-01
Classic-Craft Mahogany Primer for Rose skins	MSCCMAB
Smooth-Star Primer	MSWHSABP-03
Steel White Primer	MSWHABP-01
Steel Edge Door Primer	MSWHSED
Steel Frame Primer	MSWHAF2

Classic-Craft, Fiber-Classic and Smooth-Star Skin Repair

For minor scratches in buff fiberglass skins utilize primer (part #MSCCAB-01) to touch up.

For minor scratches in rose fiberglass skins utilize primer (part # MSCCMAB) to touch up.

For minor scratches in white fiberglass skins utilize primer (part # MSWHSABP-03) to touch up.

For deep scratches, fill with crayon or patch pencil.

Therma-Tru does not recommend any other repair procedures for composite doors.

This page intentionally left blank.

DIMENSIONS FROM TOP EDGE OF DOOR TO TOP OF HINGE MORTISES.

Door Slab	First Hinge	Second Hinge	Third Hinge	Fourth Hinge
6/6 Standard	8.344"	37.594"	66.844"	n/a
6/8 Standard				
7/0 Standard	5.219"	30.719"	56.219"	81.719"
8/0 Standard				

Mark top of hinge mortises.
(Index from top edge of door)

DOOR
PREP

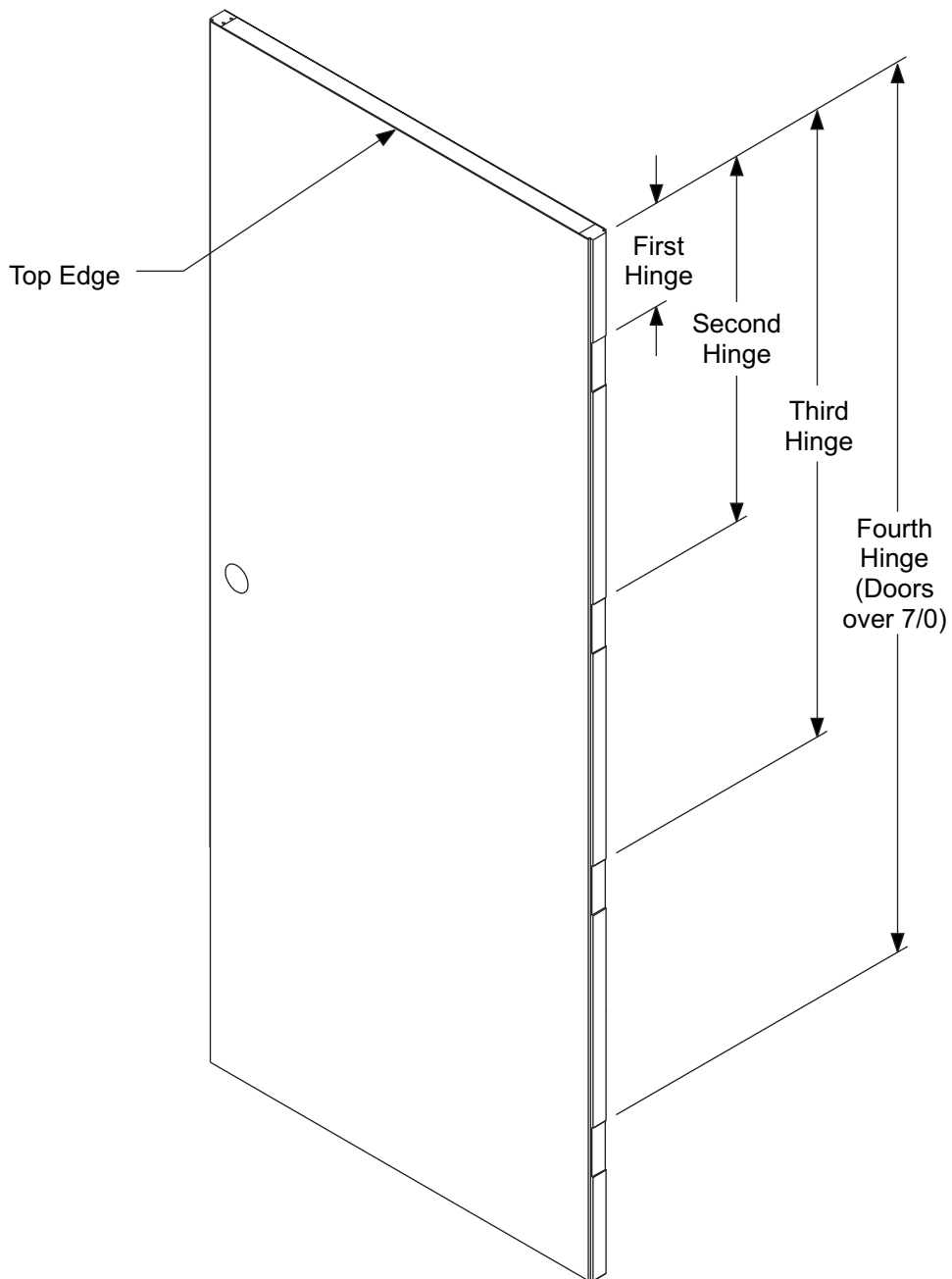

Hinge Preparation Arch Top Door

Mark bottom of hinge mortises.

(Index from bottom edge of door)

DOOR
PREP

DESCRIPTION	HINGE				OVERALL
	FIRST	SECOND	THIRD	FOURTH	
3/0 & 3/6 x 8/0 ARCHTOP	9.485	32.735	55.985	79.235	95.250
3/0 & 3/6 x 6/8 ARCHTOP	8.360	35.797	63.235	NA	79.250

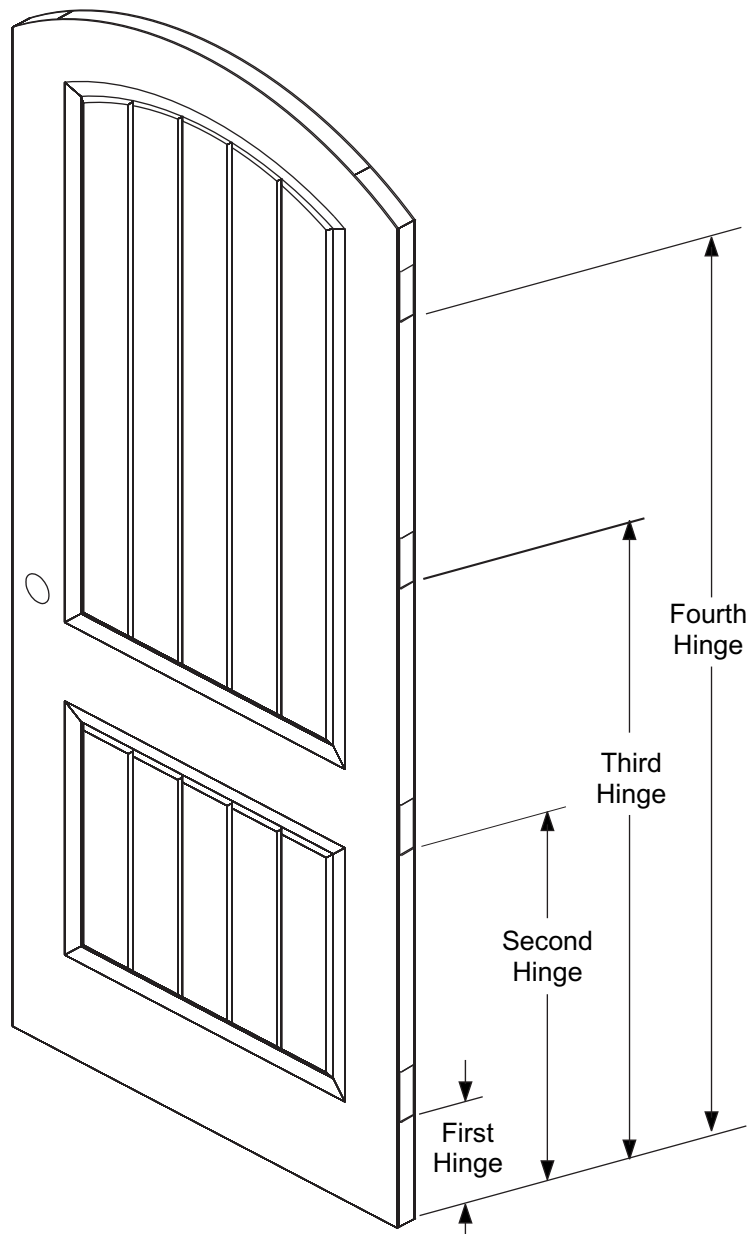

Mark bottom of hinge mortises.

(Index from bottom edge of door)

DESCRIPTION	HINGE				OVERALL
	FIRST	SECOND	THRD	FOURTH	
3/0 x 8/0 RADIUS TOP	9485	29860	50235	70610	95250
3/6 x 8/0 RADIUS TOP	9485	28860	48235	67610	95250
3/0 x 6/8 RADIUS TOP	8360	31485	54610	NA	79250
3/6 x 6/8 RADIUS TOP	7360	29485	51610	NA	79250

DOOR
PREP

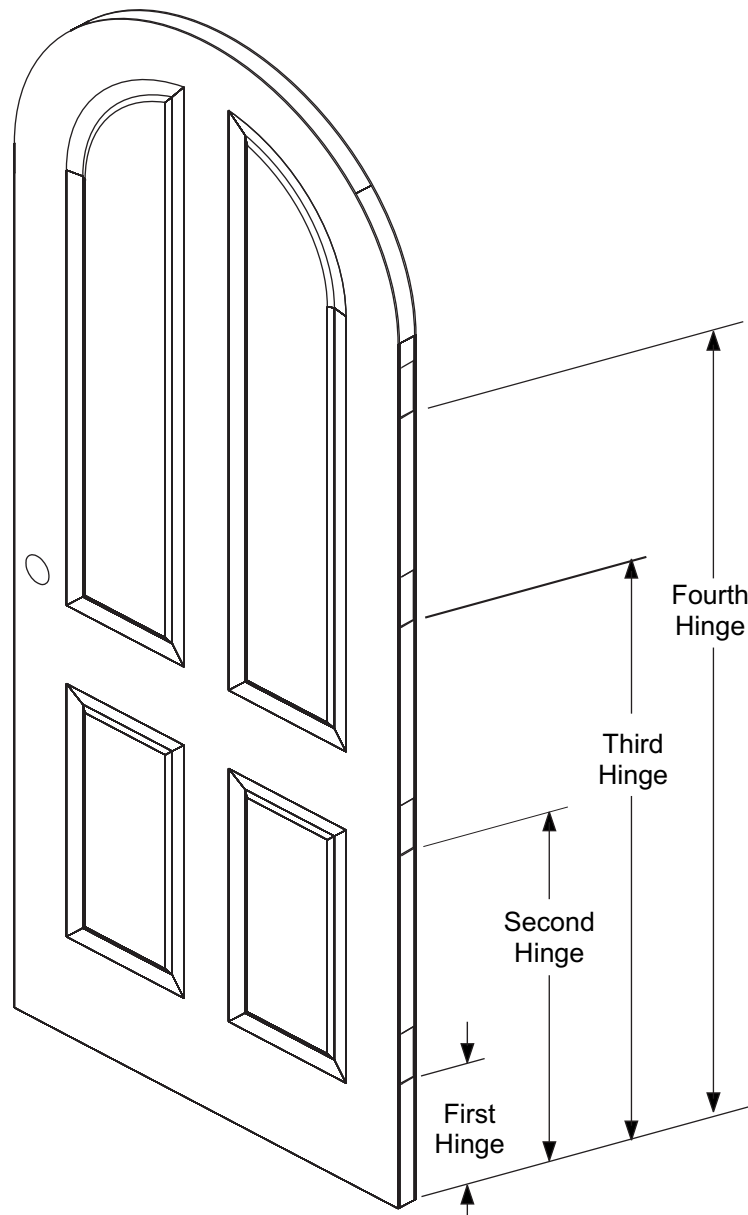

Hinge Preparation

(Except 90-Minute Steel Fire Door)

DOOR
PREP

Mark and Cut Mortises

Use a special-purpose machine or a router and template.

Pass-Through

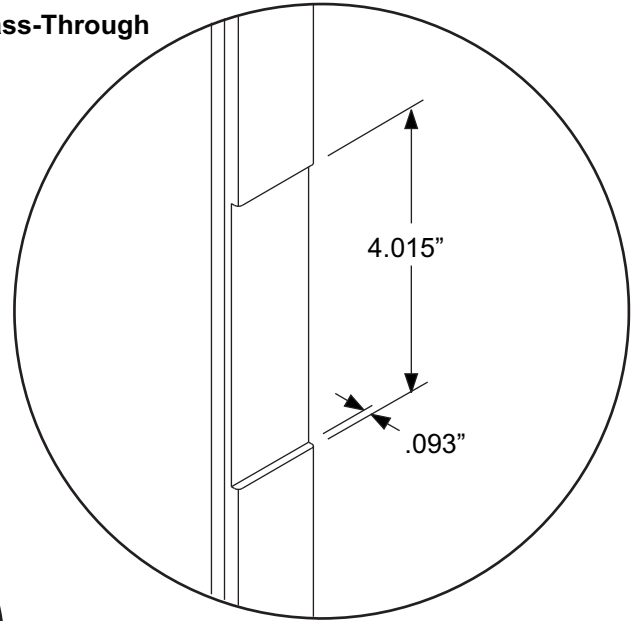

Adjustable

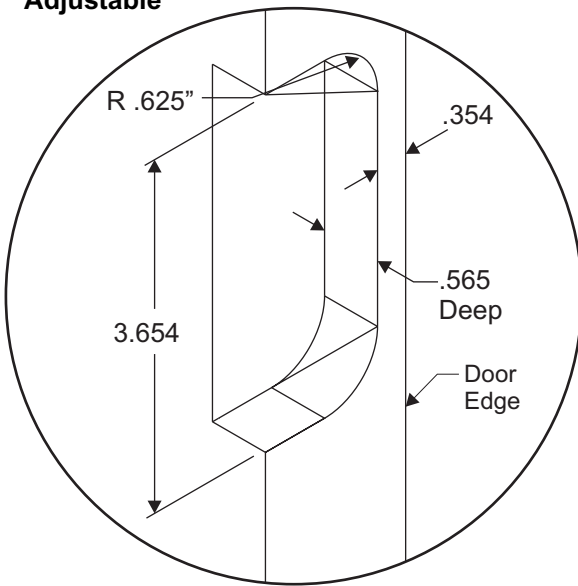

Full Mortise

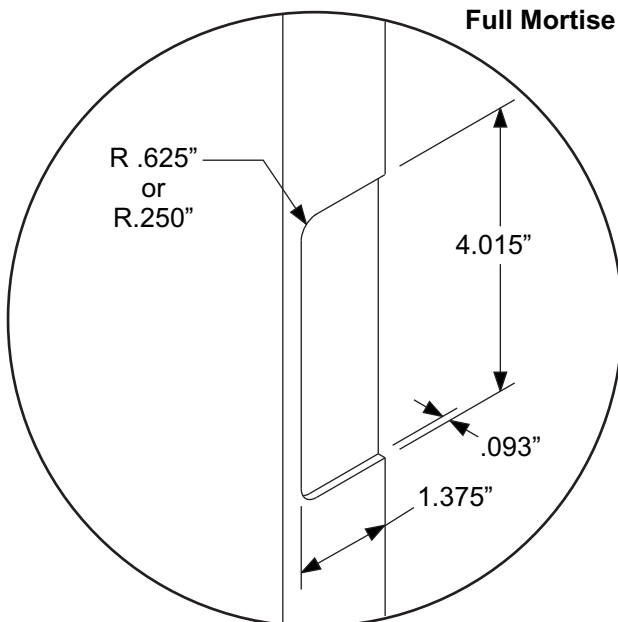

CAUTION:

Full mortises require pilot holes only if door has hardwood stiles. Refer to (SHOP 3 - Hinge Installation Full Mortise), for instructions.

NOTE:
See 90-Minute Steel
Fire Door Lock Preparation.

Mark for Lock Preparation

Preparation shown is for standard cylindrical lock sets.
For mortise locks and other types use manufacturer's
templates and instructions.



CAUTION:
Due to stile width and lite placement, some
door styles have restrictions on lock crossbore
and backset. Using the DOOR STYLE
manual, (paperback or web site), see if
restrictions apply. Deadbolt locations
and sizes vary.

NOTE:
If cutting second prep for deadbolt, spacing should be 7"
maximum for Fiber-Classic, Smooth-Star and Steel doors.
No restriction applies for Classic-Craft doors.

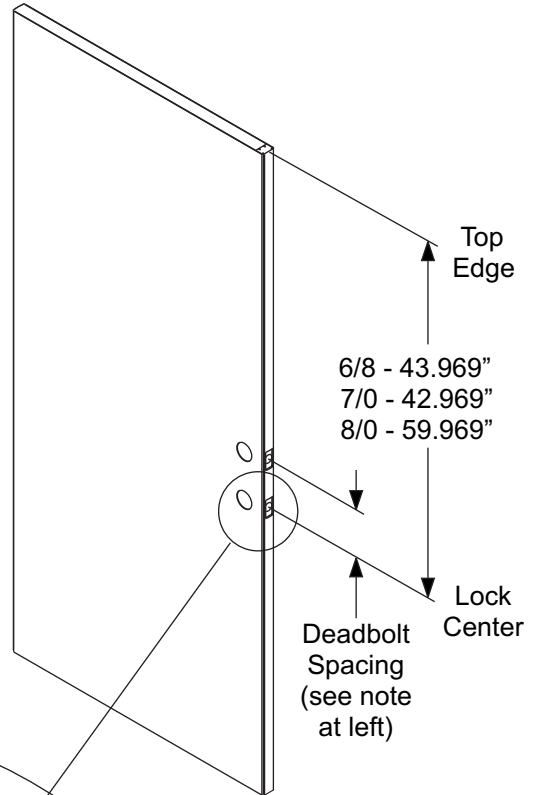

DOOR
PREP

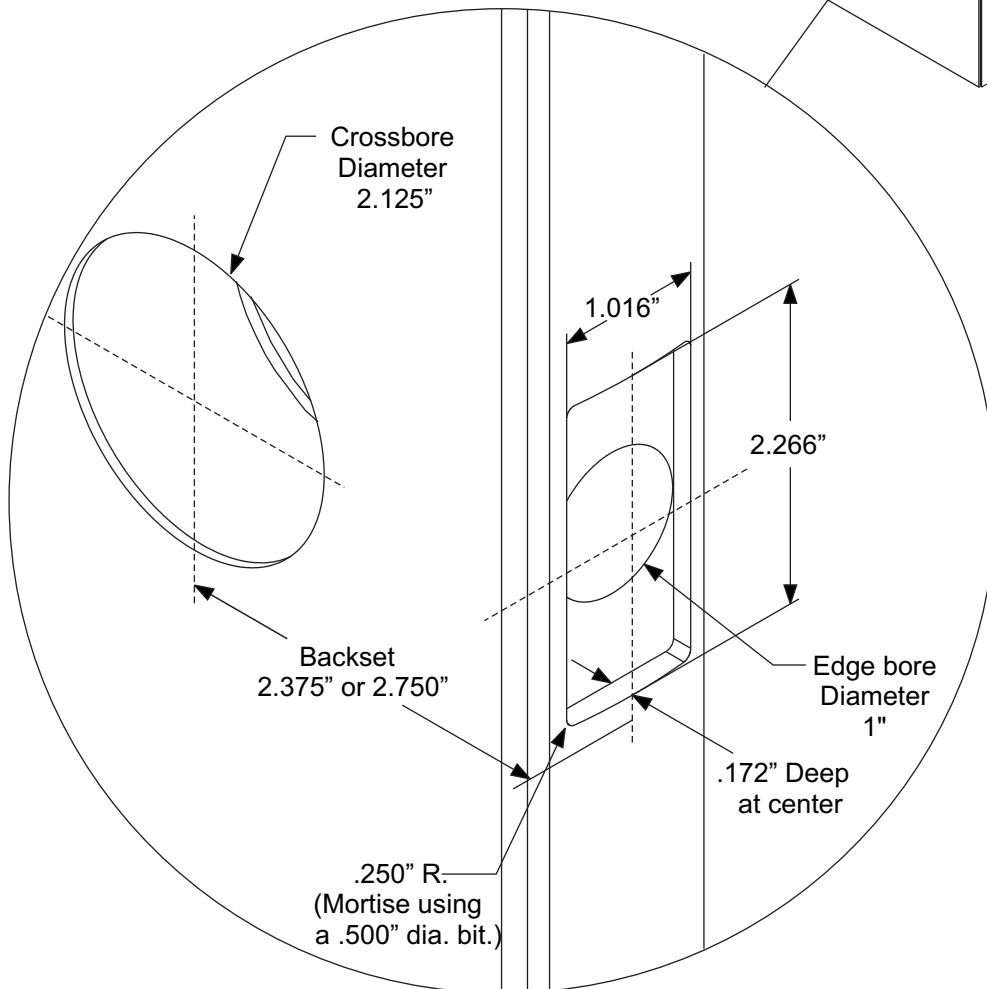

Lock Preparation (Except 90-Minute Steel Fire Door)

Drill Crossbore When Door Machine Is Not Available

Bore through half of door thickness until pilot pierces other side.

DOOR
PREP



CAUTION:

Do not bore completely through to other side of door.

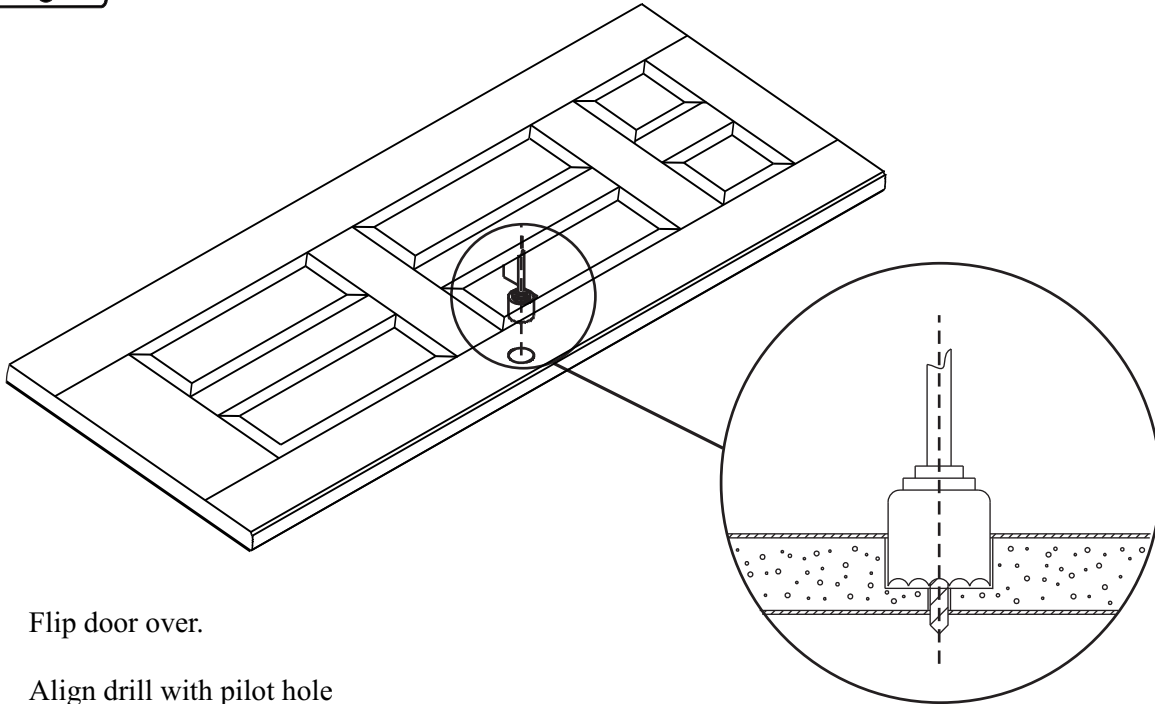

Flip door over.

Align drill with pilot hole and complete boring.

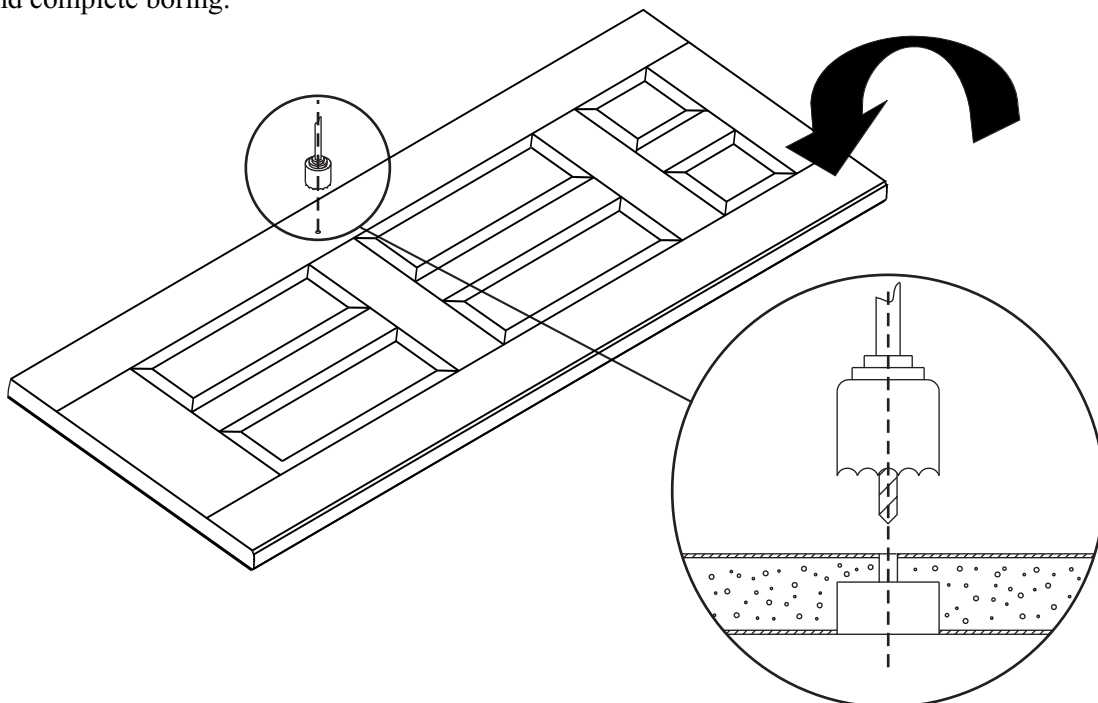

Mark for Lock Preparation

Preparation shown is for standard cylindrical lock sets. For mortise locks and other types use manufacturer's templates and instructions.



CAUTION:
Due to stile width and lite placement, some door styles have restrictions on lock crossbore and backset. Using the DOOR STYLE manual, (paperback or web site), see if restrictions apply. Deadbolt locations and sizes vary.

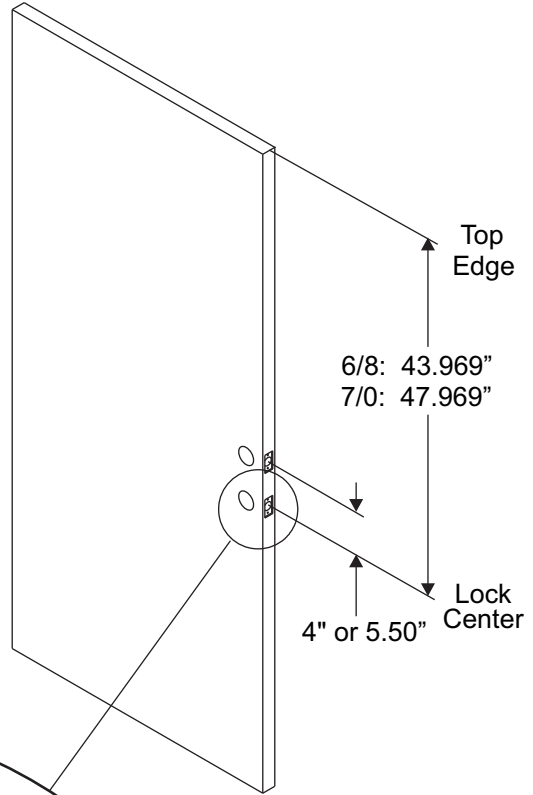

DOOR
PREP

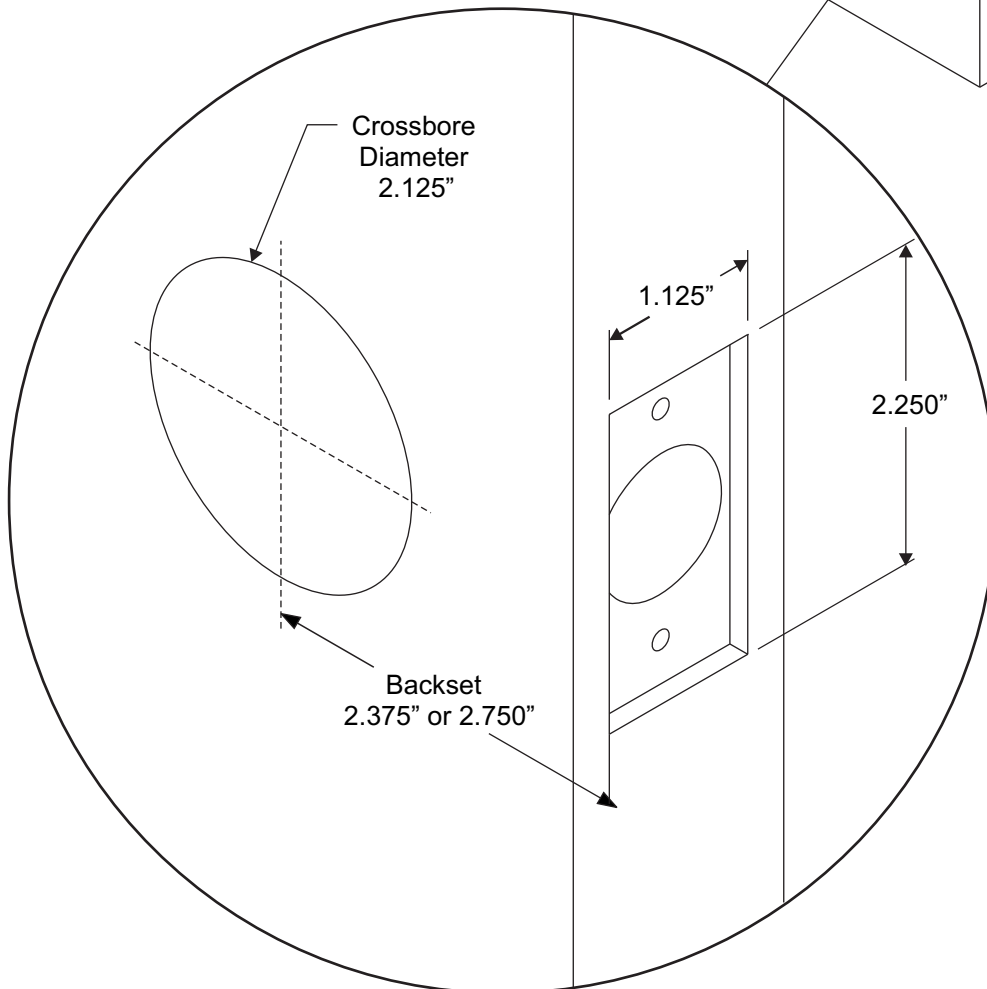

Lock Preparation - 90-Minute Steel Fire Door



CAUTION:

Only shops licensed as fire door machiners may perform this lock preparation.

Drill Crossbore When Door Machine Is Not Available

Bore through half of door thickness until pilot pierces other side.



CAUTION:

Do not bore completely through to other side of door.

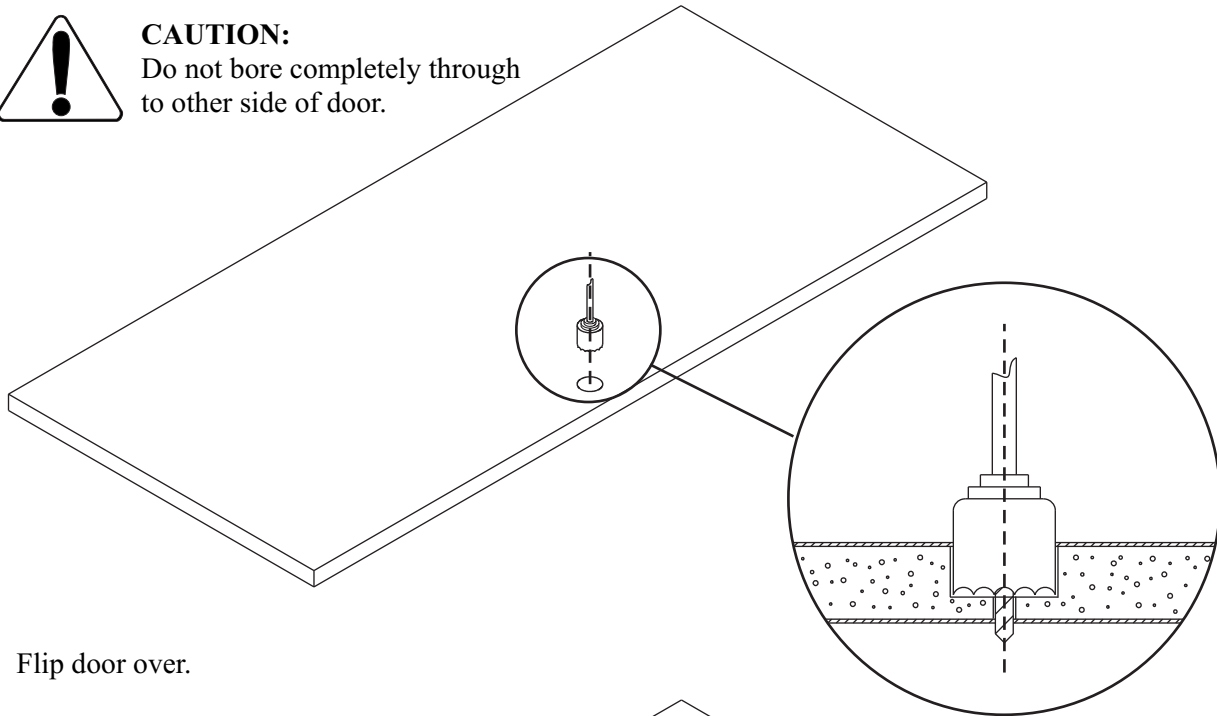

Flip door over.

Align drill with pilot hole
and complete boring.

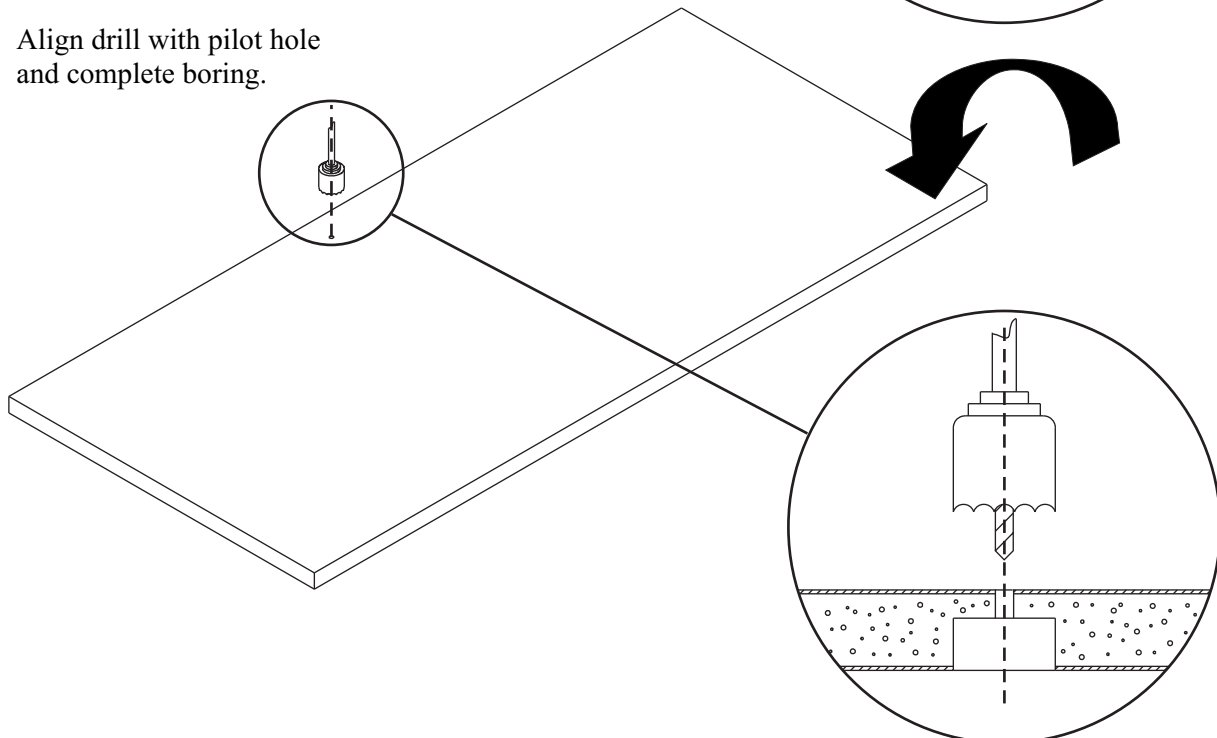

Multipoint Lock Preparation

Preparation shown is for Therma-Tru multipoint lock set door preparation only. Jamb preparation is shown in individual unit preparation sections. Use this as a reference guide along with the manufacturer's templates and instructions.

NOTE:

Multipoint Lock Systems recommended only for Fiberglass Products including: Classic Craft, Fiber-Classic, and Smooth-Star.

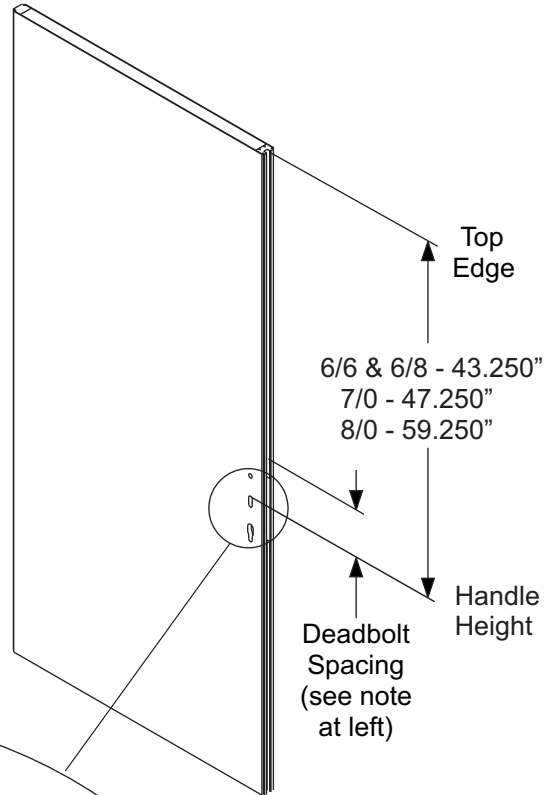

DOOR
PREP

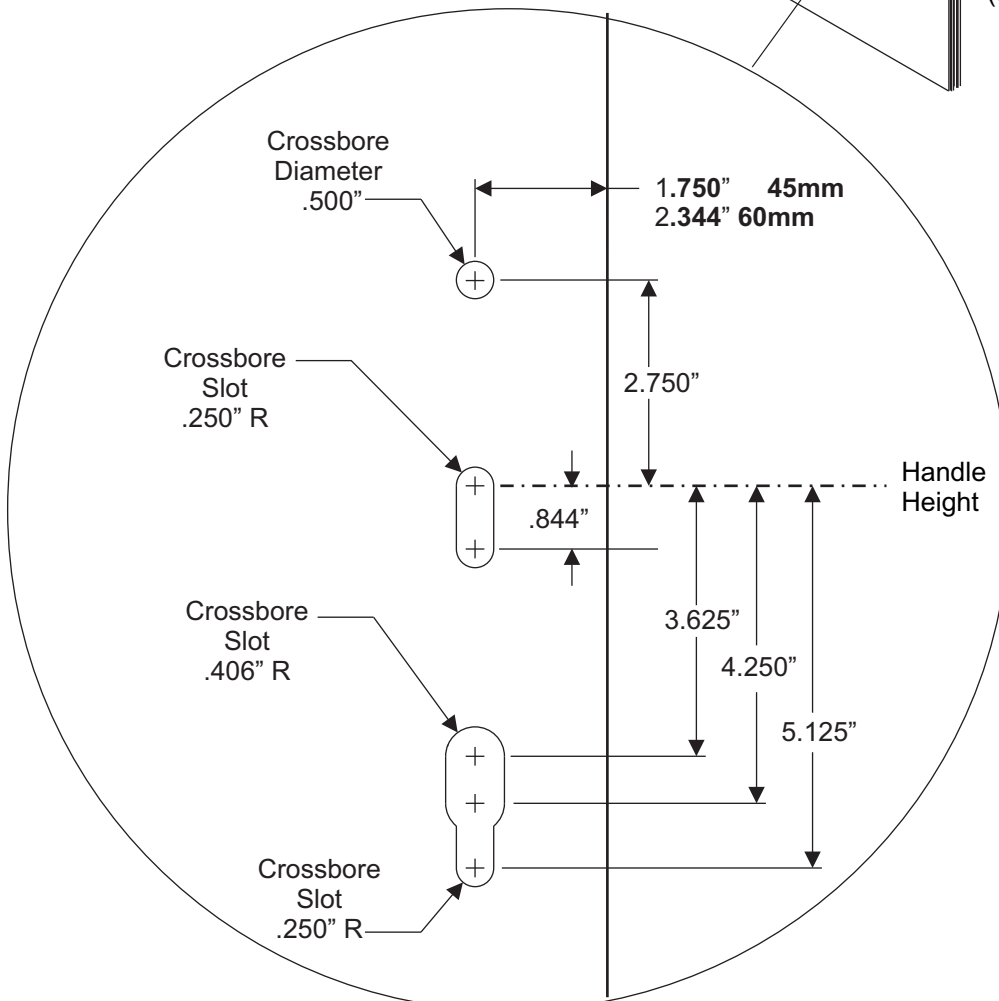

Multi-Point Lock Preparation (Except Fire & Steel Doors)

DOOR
PREP

Eurogroove Preparation

Set Router Bit Depth & Adjust Guide Fence

Set the bit depth using the manufacturer's guide that came with the router. The depth of the route should be 12mm (roughly 15/32").

Note: Test the route depth on a scrap piece of wood.

Adjust the guide fence so that the assembly can slide down the entire length of the door.

Note: If binding occurs, readjust the fence at the thickest section of the door.

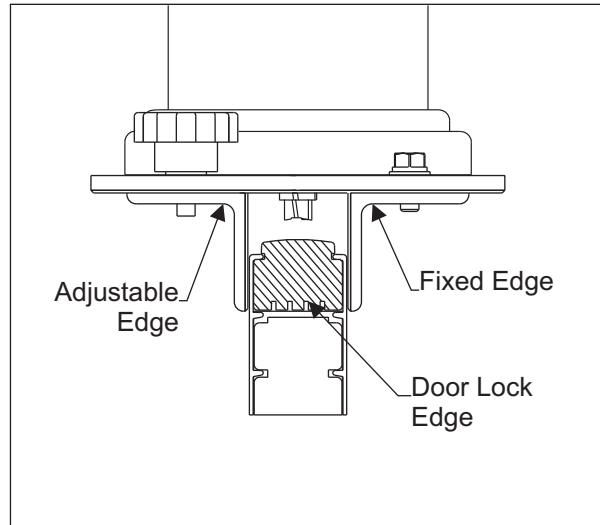

Secure Door on Edge & Apply Router & Guide Fixture

Set assembly on the door panel and move it until the bit reaches the door edge. Move the assembly away from the door edge so that the bit is not in contact when the router is started.



CAUTION: The fixed edge guide for the Eurogroove Router and the fixed edge of the Gear & Handle Mortise Jig must be located on the same side of the door during the preparation. Failure to do so could result in off-center relationship of gear mortise and eurogroove.

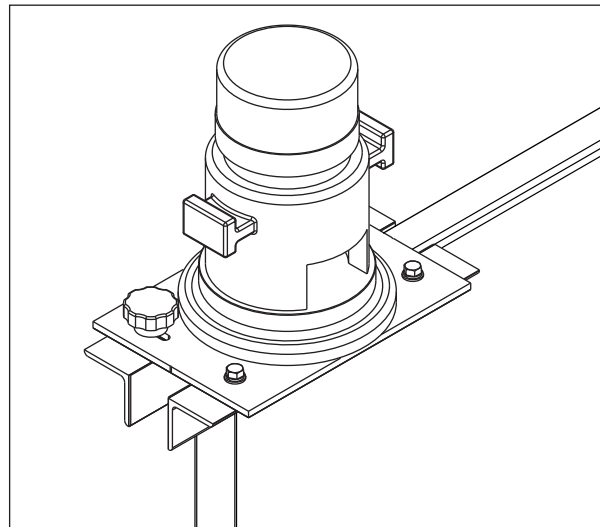

Cut Eurogroove

NOTE: For best results, set the router at maximum RPM.

Route the entire length of the door edge. Apply constant pressure against the fixed edge of the router fence for best results. Remove the sawdust after the cut is complete.

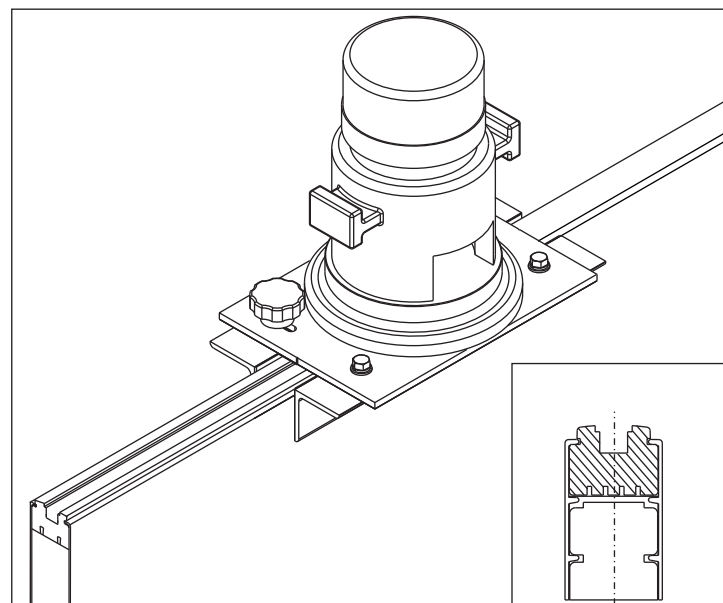

Gear Mortise Preparation

Apply Cross Mortise Fixture

Set the cross mortise jig on the edge of the door and slide up until the lock height setting bolt has contacted the bottom edge of the panel. Carefully tighten the adjustment knob enough to secure the jig to the panel.

NOTE: Over tightening can cause the width of the mortise pocket to be cut improperly.

NOTE: Be sure the jig is flat against the edge of the panel and tight against the bottom to provide proper placement of the handle mechanism.

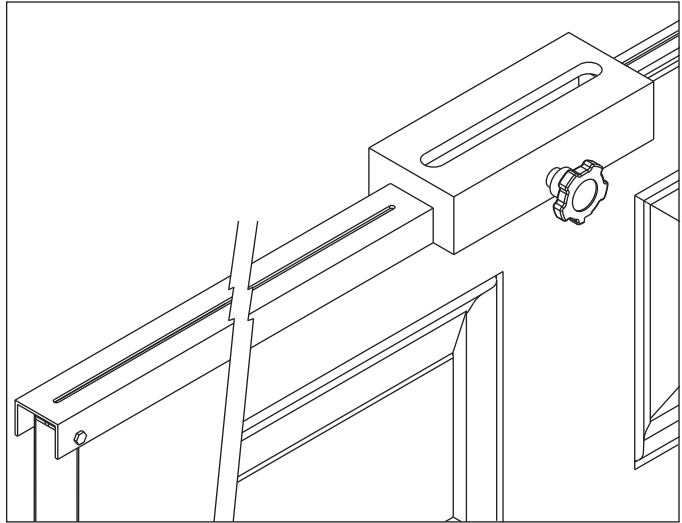

DOOR
PREP

Set Up Plunge Router

Set the depth of cut using the manufacturer's guide that came with the plunge router. The depth of the route should be 64mm (approximately 2-9/16" for 45mm & 3-7/32" for 60mm) using a 1/2" cut by 5-1/2" long bit with a 3/16" collar.

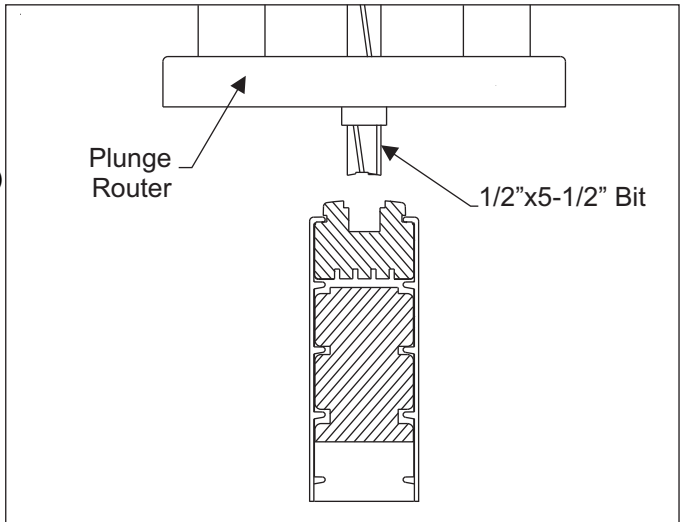

Cut Gear Mortise



CAUTION: The router bit will extend past the base of the router. Make sure the router is sitting firmly in the jig before starting the router. Let the router come to a complete stop before removing from the jig.

Slide the bit into the opening on the jig and make cut using several passes along the guide to obtain the proper depth.

Note: It is recommended to cut 1/4" - 1/2" each pass.

Coat Eurogroove



CAUTION: Coat entire length of Eurogroove & gear mortise with water sealant, per the manufacturers guide, to prevent moisture absorption.

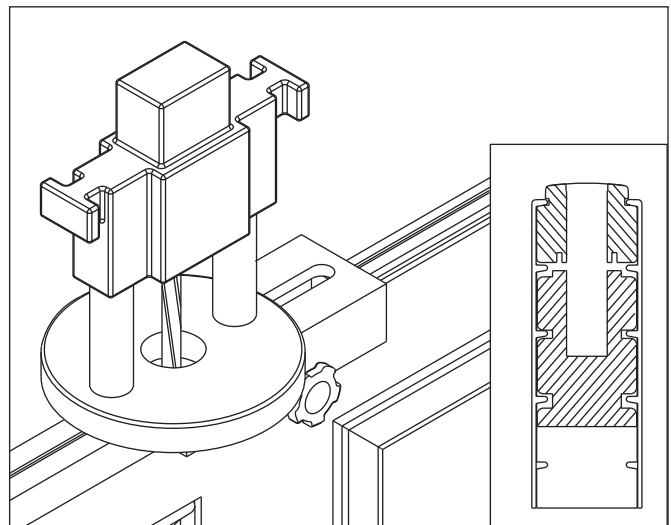

Multi-Point Lock Preparation (Except Fire & Steel Doors)

DOOR
PREP

Trim Set Preparation

Cut Trim Set Holes

Using the same cross mortise jig set up, place the door laying flat on a table to ease this portion. Reset the plunge router bit to allow the guide to rest completely flat on the face of the jig and route all holes through the face of both sides of the door panel.



CAUTION: The router bit will extend past the base of the router. Make sure the router is sitting firmly in the jig before starting the router. Let the router come to a complete stop before removing from the jig.

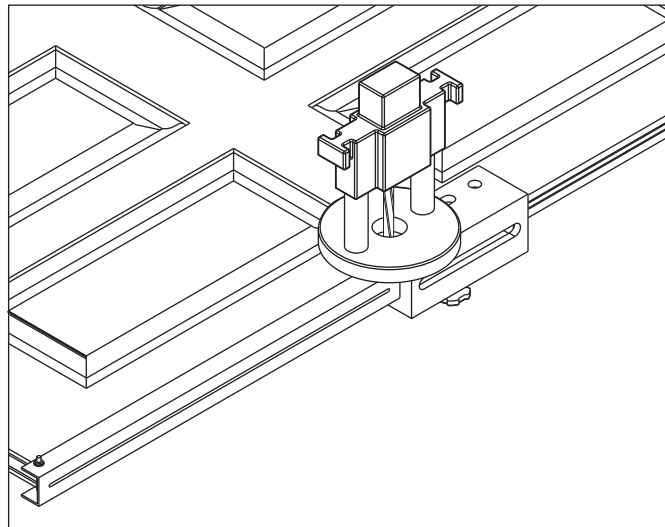
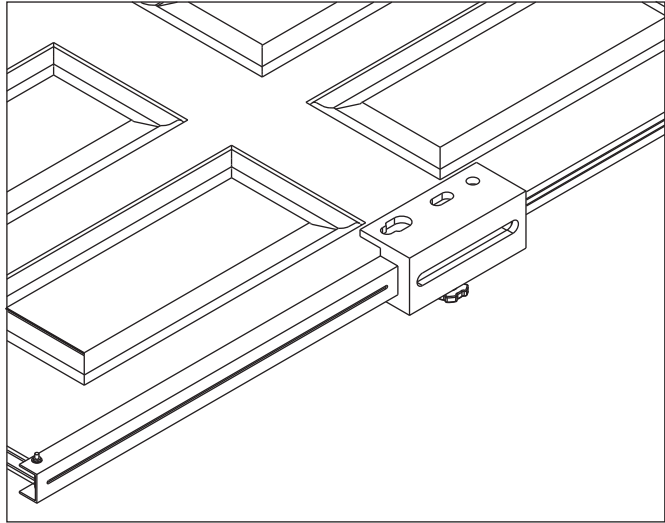

Step 1 - Sidelite Handle/Mortise Jig

Tools Required:

- Plunge router with 1/2" bit and 13/16" collar (Provided in door kit)
- Drill bit 7/16"
- Drill bit stop (provided)
- 1/8" Hex head wrench

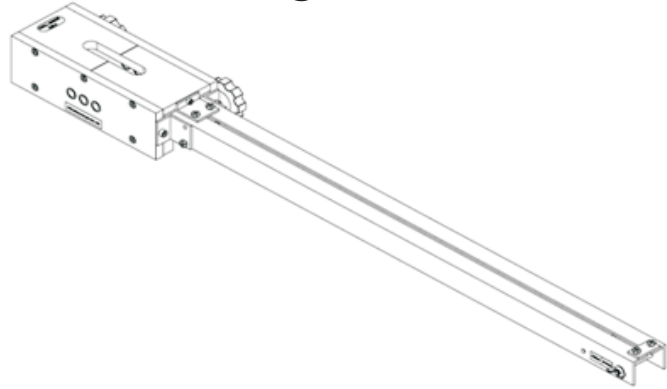

DOOR
PREP

Power Tool Notes:

Remember to always follow the safety and operation instructions of the equipment manufacturers.

Using the information given below, determine the handle position. Place the pin in the hole at the bottom that is marked with the correct handle height. Attach the wing nut to the pin to secure it in place.

Set the router plunge depth to 50.5 mm (1.988").

Slide the drill stop over the 7/16" drill bit and then rest the bit on the top of the jig. The bit should extend to a depth of 31.75 mm (1.250") or 1 1/4" into the sidelite. Tighten the stop with a 1/8" hex head wrench. Adjust if needed after your first use.

Note: With a sidelite system the thumb turn is on the interior side only. As a safeguard, the jig has this instruction etched on the top. Drill from the **interior side only**.

Slide the jig over the lock stile of the sidelite such that the locator pin is resting against the bottom rail.

Ensure the base of the jig is sitting flat on the sidelite. The handle placement arm does not sit on the panel. Do not push down on that since it may tip the base slightly. Turn both black knobs until the jig is firmly clamped to the panel. **Do not overtighten.**

Using the 7/16" drill bit with drill stop, bore the 3 handle holes on the inside surface of the door. **Do not drill all the way through the sidelite.**

Plunge route the top slot to a depth of 33.5 mm (1.3") or 1 5/16". For best results, use multiple passes to avoid chipping out the wood.

Remove jig, clean out the saw dust, and install multipoint locking hardware and thumbturn.

UNIT SIZE	HANDLE HEIGHT
6/6	33.434
6/8	35.982
8/0	35.982
6/8 U1	35.982
8/0 U1	35.982

Step 2 - Sidelite Eurogroove Machining

Tools Required:

- Eurogroove router
(Provided in door kit)
- Eurogroove Stops

DOOR
PREP

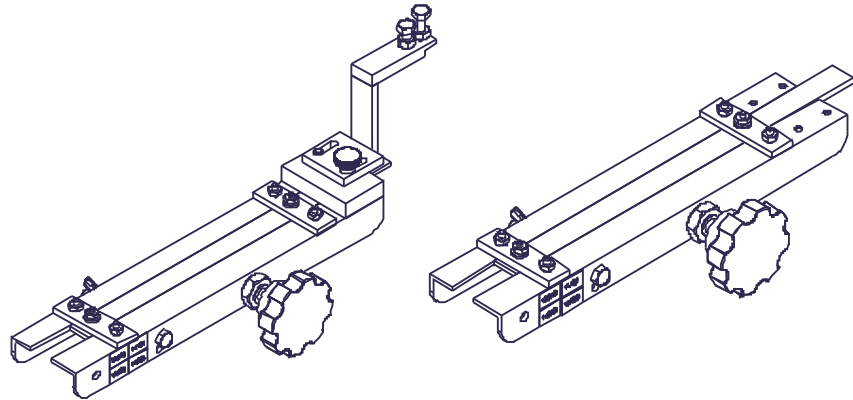

Power Tool Notes:

Remember to always follow the safety and operation instructions of the equipment manufacturers.

Using the information provided below, determine the distance from each end that the Eurogroove should stop.

For lengths less than 5", the wing nut is removed from the two piece jig, which is then clamped to the top surface of the sidelite. The two adjustable nuts are then used for the stop locations.

For lengths greater than 5", place the pin with the wing nut in the hole that corresponds with the desired distance. The one piece jig is then clamped to the lock side of the sidelite.

Place the router on the sidelite stile with the bit extending into the hole machined in Step 1. Then machine the Eurogroove, stopping the router when the base plate hits each stop.

UNIT SIZE	BOTTOM STOP	TOP STOP
6/6	12.562	2.394
6/8	15.110	2.394
8/0	15.110	15.402
6/8 U1	15.110	2.191
8/0 U1	15.110	15.199

Note: DP300CC used on CC30300 only. DP300CCM used on CCM30300. Temperature range for optimal tape adhesion is 70° to 100°F. Minimum suggested application temperature is 50°F.

- 1. Moisten a clean cloth with 70% Isopropyl Alcohol. Wipe flat surface around entire perimeter of opening. Allow to dry.**



Not preparing door will result in poor panel adhesion.

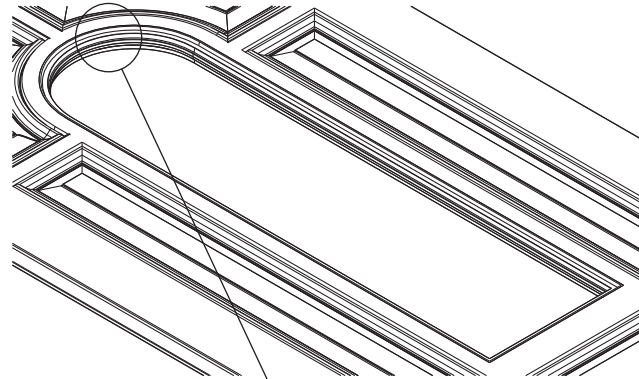

DOOR
PREP

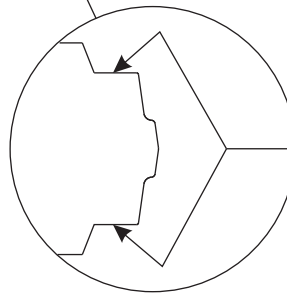
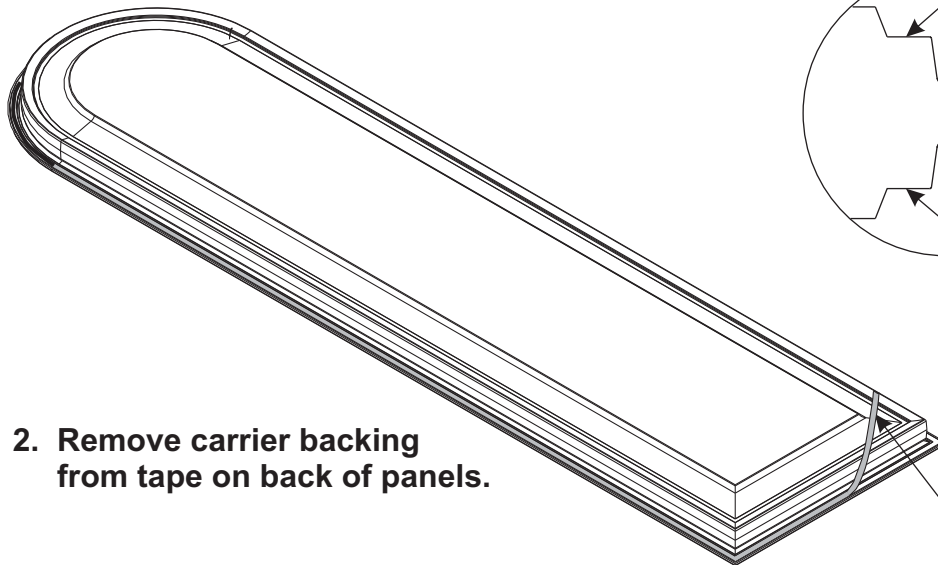

Clean flat surface all around perimeter with alcohol

- 2. Remove carrier backing from tape on back of panels.**

- 3. Position panel in opening and press down firmly around outside edges.**

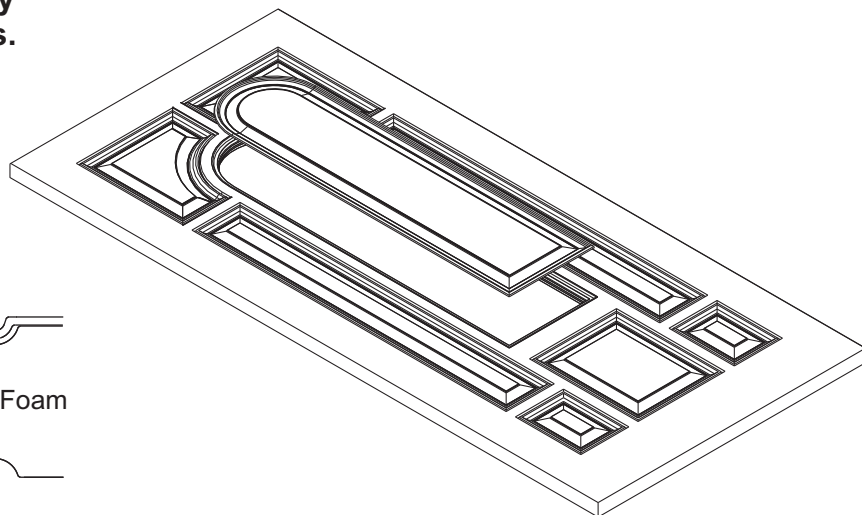
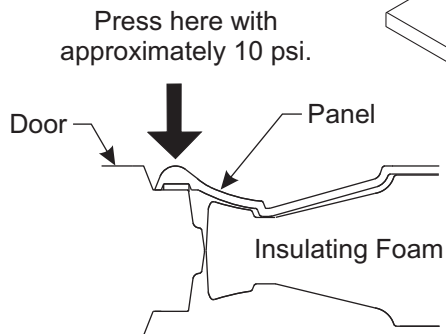

4. Flip door over.
5. Apply two (2) beads of structural adhesive to back of panel.

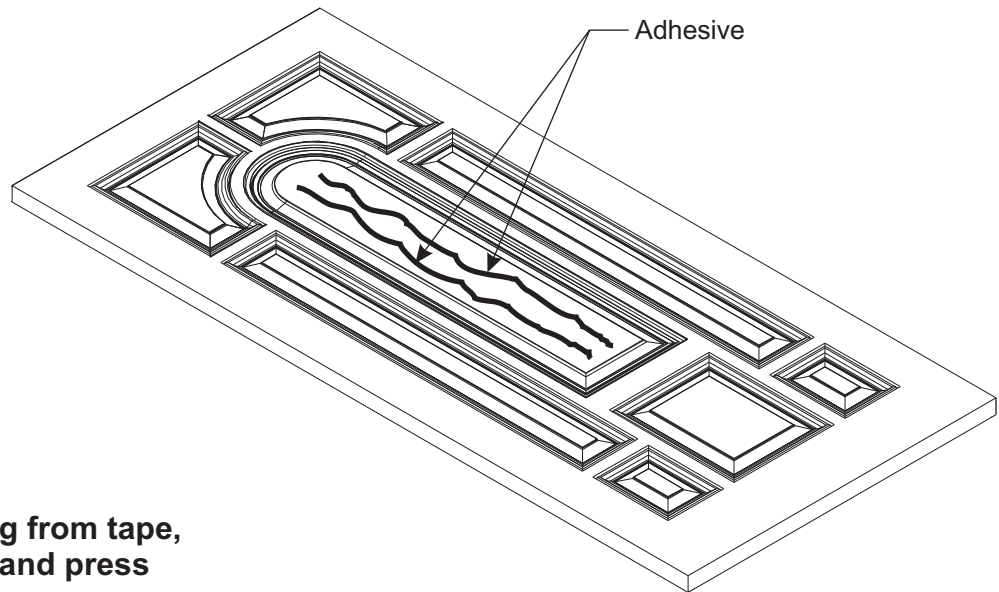

6. Remove backing from tape, position panel, and press firmly into place.

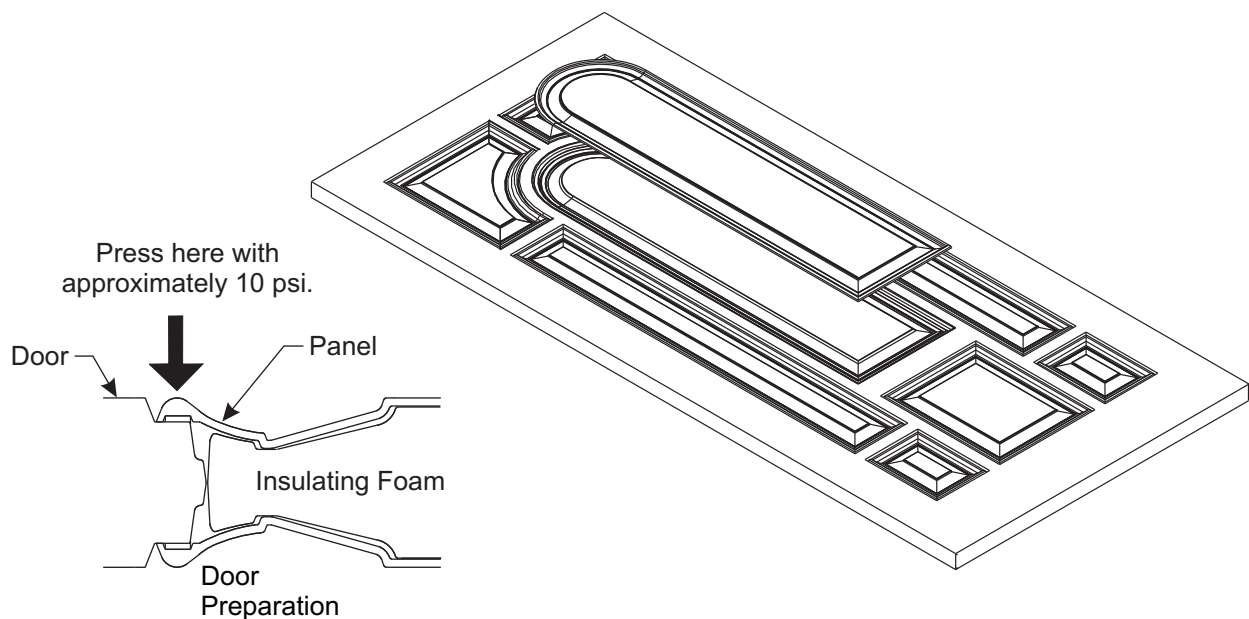

Select the correct template to match the door style. Refer to SHOP 11.



CAUTION:

If door was resized, template use may be affected. Template location is referenced from the top of the door and embossed pattern adjustments may be necessary. Template should always be centered from side-to-side.

DOOR
PREP

Align Template

Place template on door slab.

Center template on slab using corner or notches to align.

Align template with top of door and edge of hinge side.

Offset and center template, side-to-side, if cutting an undersized door.

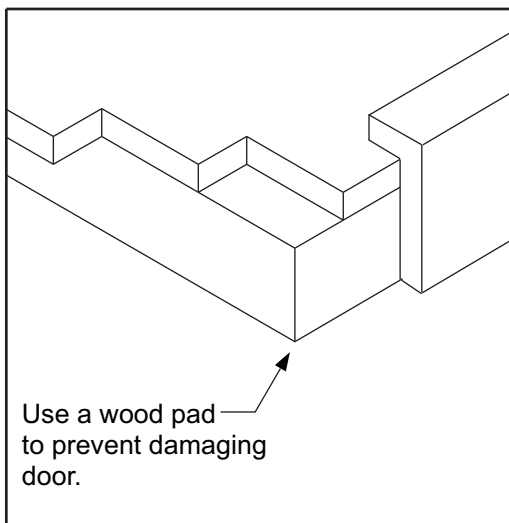
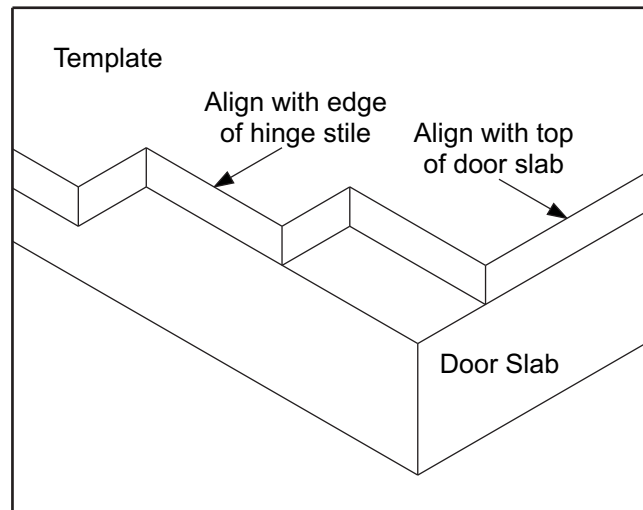

Clamp Template to Door

Clamp mechanism and door support table shown here are typical for Ruvo/Triad door cutout machines.

Doorlite and Panel Preparation

DOOR
PREP

Cut Slab for Doorlites or Panels

All templates are designed for use with standard cutout machines. Template openings are offset exactly 1/2" from cutout edges.

Check templates periodically for wear and replace when required. Refer to SHOP 11 for cutout size specifications.

Modify heavily used templates by adding metal or wear-resistant plastic to edges. Relieve template edges to allow for wear plate thickness.

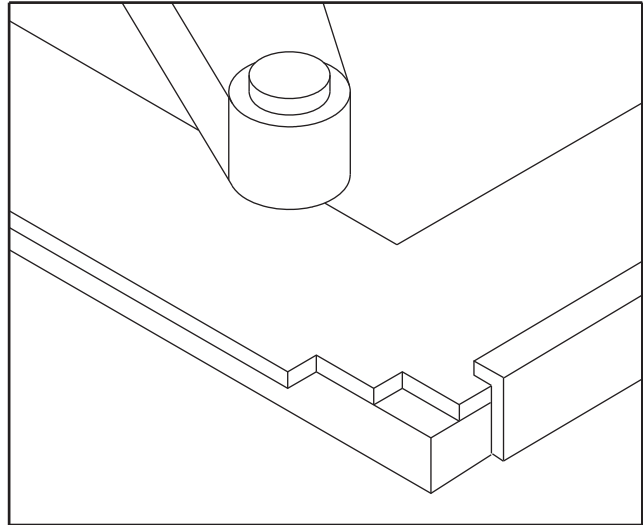



Always place door in HORIZONTAL position before removing lite or panel.

Separate Lite or Panel Frames

Remove screws or staples to separate lite or panel frames.

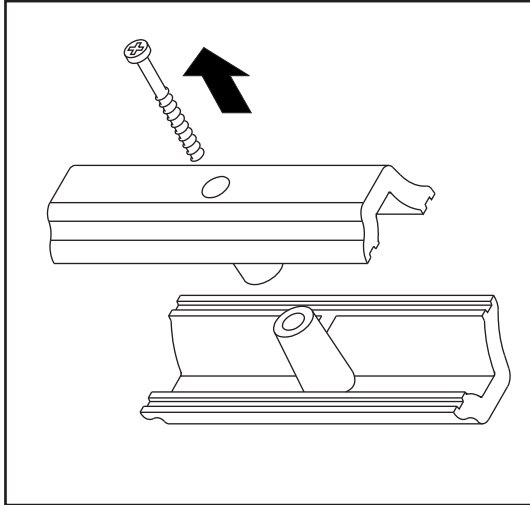

DOOR
PREP

Apply Glazing Tape to Entire Perimeter of Exterior Frame

If not factory applied, apply foam glazing tape (Part No. RPGLZTP).

DO NOT stretch.

Overlap at corners.

Press on lightly with fingers. Then with a roller tool, fully bond gasket using firm pressure.

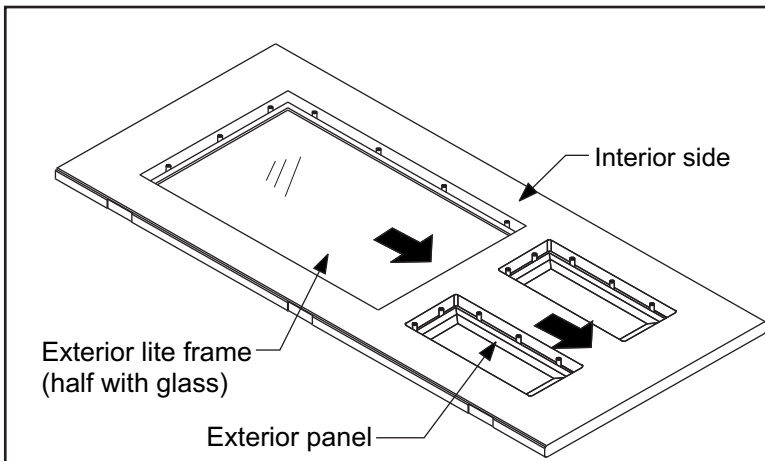
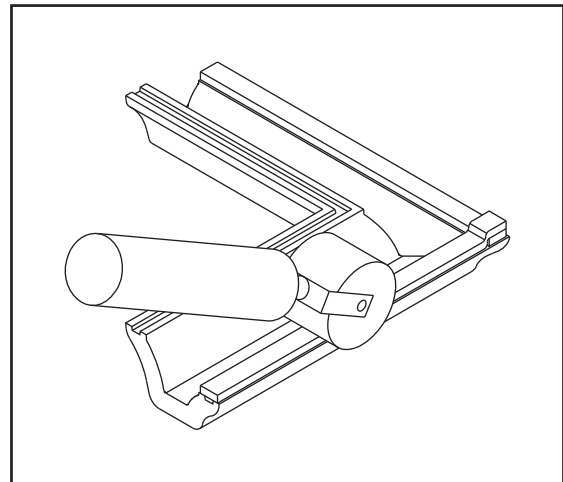

Position Lite/Panel into Opening

Place lites and panels against bottom edge of cutouts to prevent shifting.

Center lites and panels in cutout, side-to-side

Doorlite & Designline Panel Installation

DOOR
PREP

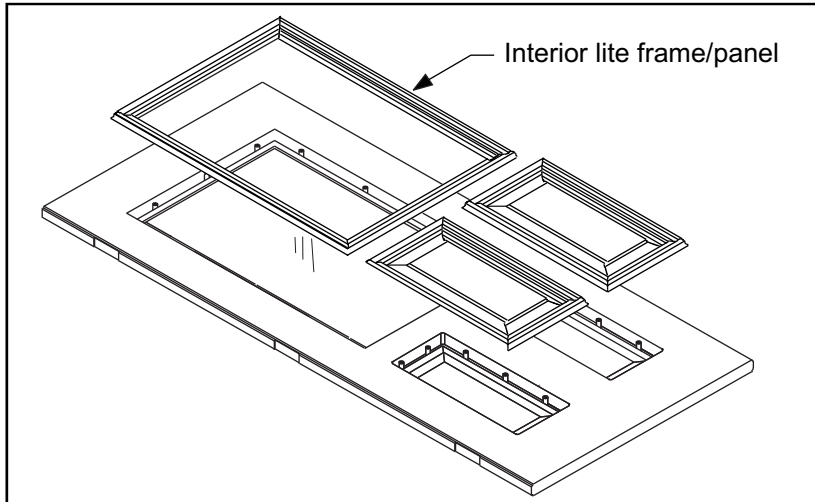

Position Interior Sides of Frames and Panels

Ensure correct alignment of
screw bosses.

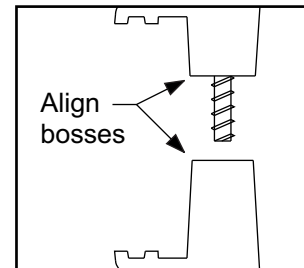

Select the Right Screw

Use the correct screw with the appropriate lite frame. (Fasteners are shown actual size.)

For this lite

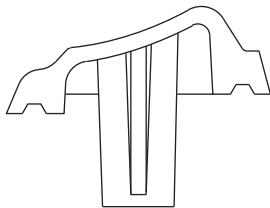

Classic-Craft Doorlite
(for molded opening)

Use this fastener

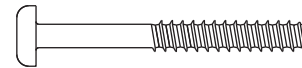

Part # SCSMC750

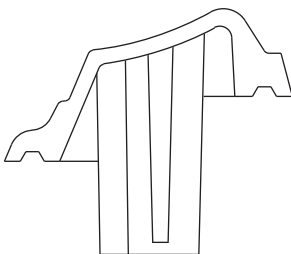

Classic-Craft Doorlite
(for surface mount)



Part # SCSMCL

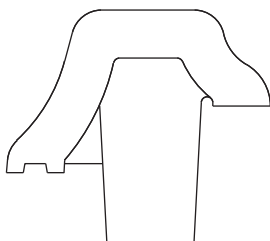

Fiber-Classic Doorlite
Smooth-Star Doorlite
Steel Doorlite

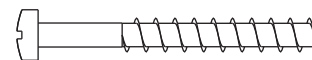

Part # SCDL000

Select the Right Screw

Use the correct screw with the appropriate lite frame. (Fasteners are shown actual size.)

For this lite

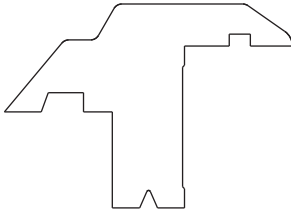

Fiber-Classic Doorlite
without Screw Bosses

Use this fastener

Brass Finish
Entire Screw

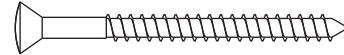

Part # RPSCFCLDL

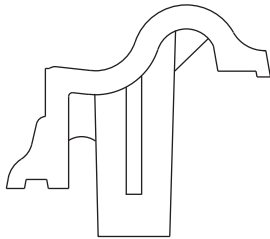

Fiber-Classic, Smooth-Star
and Steel Doorlites

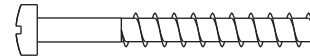

Part # SCDL000

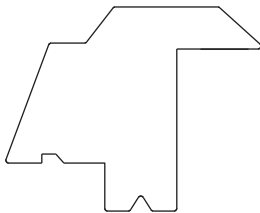

Smooth-Star and
Steel Doorlites
without Screw Bosses

White Painted Head

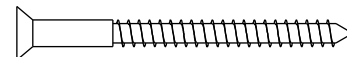

Part # RPSCLDL

For this panel

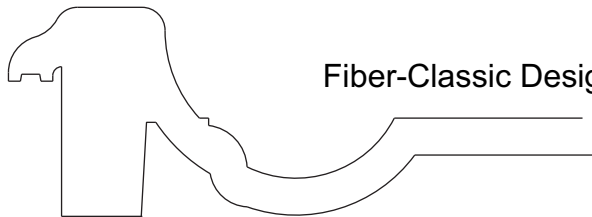

Fiber-Classic Designline Panel

Use this fastener

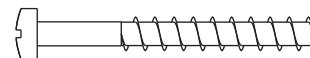

Part # SCDL000

DOOR
PREP

Select the Right Screw

Use the correct screw with the appropriate lite frame. (Fasteners are shown actual size.)

DOOR
PREP

For this lite

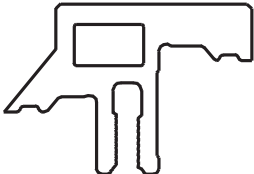

Wrought Iron Doorlite

Use this fastener

Part # CCRSCREW

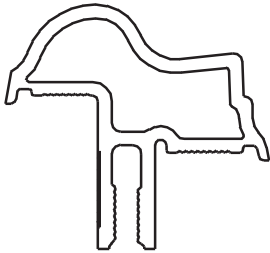

Impact Doorlite



Part # SCCCA150

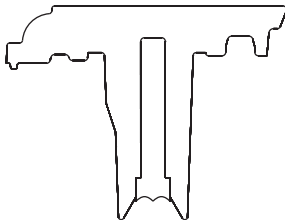

Flush Fit Doorlite

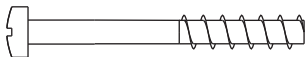

Part # SCDL100

Adjust Screwgun Torque



CAUTION:
DO NOT exceed
maximum torque.

MAXIMUM AND MINIMUM TORQUE SETTINGS

Doorlite	Torque (in-lbs)
Classic-Craft	9-12
Classic-Craft Wrought Iron & Impact	67-70
Fiber-Classic, Smooth-Star & Steel	12-14
Flush Fit Frame	12-14

DOOR
PREP

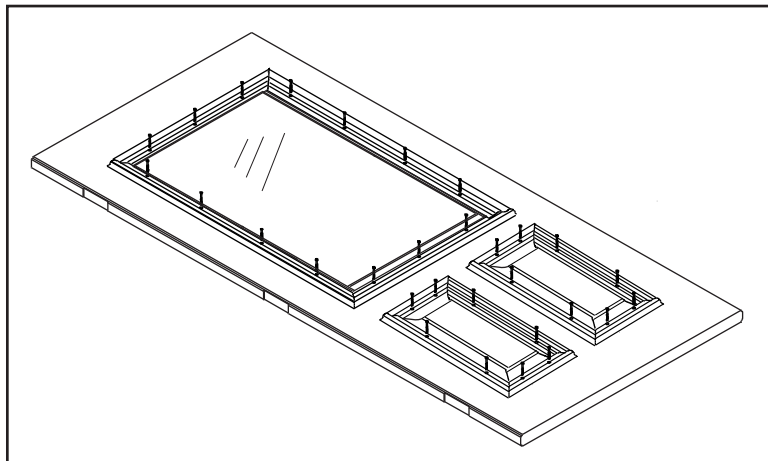

**Drive Screws with #2
Phillips Bit**

Ensure frame edges are well-seated.

NOTE:
Doorlites may be shipped with only
enough screws for safe transport.
Additional screws may be made up
from bulk supply.

Flush Fit™ Frame Installation Instructions

DOOR
PREP

STEP 1:

Unpack the glass and frames. Remove all shipping protection.

STEP 2:

Lay the exterior frame/glass on a clean door preparation table.

STEP 3:

Lay door panel over the exterior frame/glass, aligning the opening of the door over the exterior lite frame.

STEP 4:

Place aluminum rails over the screw bosses of the frame, orienting the door side of the rail (identified by the stamp) along the door edge and the non-labeled side on the glass side. Drive screws through each center hole of the aluminum rail into each screw boss of the exterior frame. The torque for each screw is to be 12-14 in-lbs.



IMPORTANT! The aluminum rails are NOT symmetrical. The edge of the rail with the tape MUST be aligned on the door side.

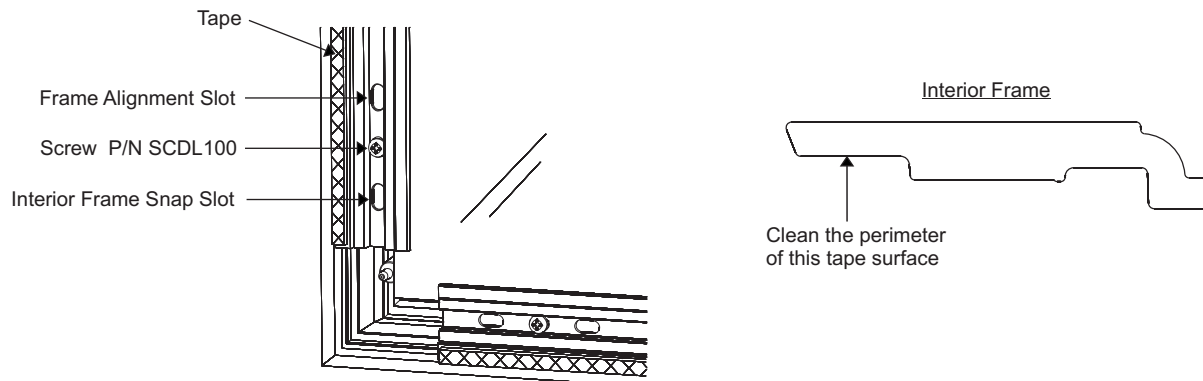

STEP 5:

Moisten a clean cloth with 3M Primer 94 or use the ampule applicator. Wipe tape surface around entire perimeter of interior frame. Allow to dry.

Refer to 3M Primer 94 MSDS for product handling and safety requirements.

Remove the carrier backer from tape on the aluminum rails.

Align the interior frame over the opening of the door, using the alignment pins for reference.

STEP 6:

Carefully snap the interior frame into place, to give a flush fit appearance.

Use a j-roller and apply pressure around the perimeter of the lite frame to ensure the frame and tape properly adhere together.

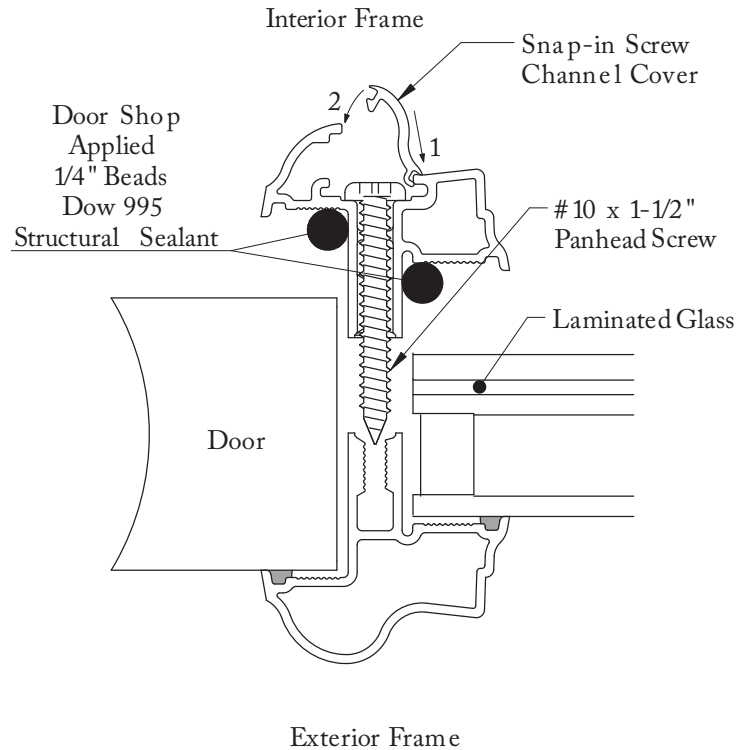

SCREW CHANNEL COVERS:

- (1) Place short side of miter to inner edge of frame.
 - (2) Rotate cover down snapping long side of miter into place.
- NOTE: Fine tuning of lengths may be needed to acquire optimal fit.

The interior frame only must be wet glazed to door slab and insulated glass unit as shown with Dow 995 structural sealant. Minimum 1/4" beads are required.

Assemble with #10 x 1-1/2" pan head screws. Screws to be tightened at 70 in. lbs.

NOTE: Laminated glass must be facing the interior frame and the structural sealant.

Hinge Installation

DOOR
PREP

Use the Correct Leaf

Leaves applied to door have 2 knuckles.

Leaves applied to jamb have 3 knuckles.

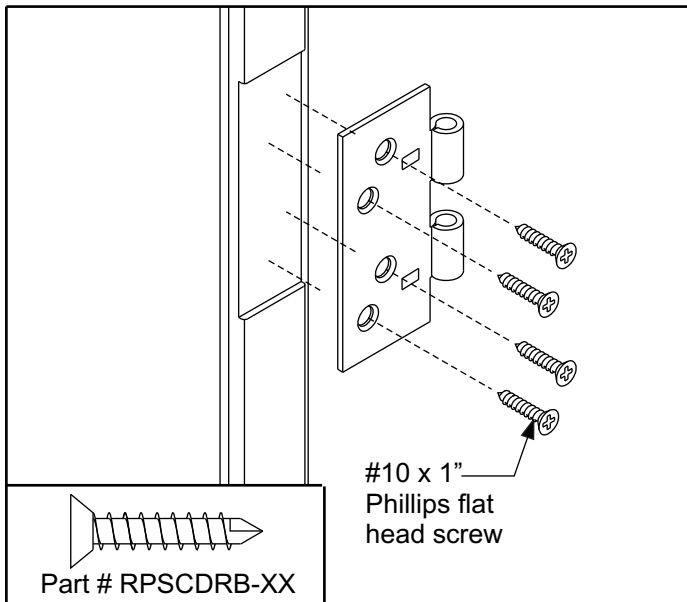
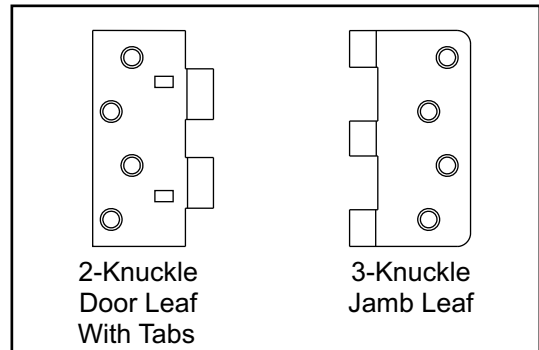

Pass-Through Mortise

Align and Install Hinges

Place tabs firmly against door skin.

Fasten 2-knuckle hinge leaves with proper screws.

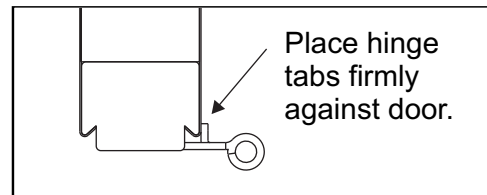

Full Mortise

Align and Install Hinges

Use mortises to properly align 2-knuckle hinge leaves.

Drill 1/8" diameter pilot holes if mounting hinges to hardwood stiles.

Fasten 2-knuckle hinge leaves with proper screws.

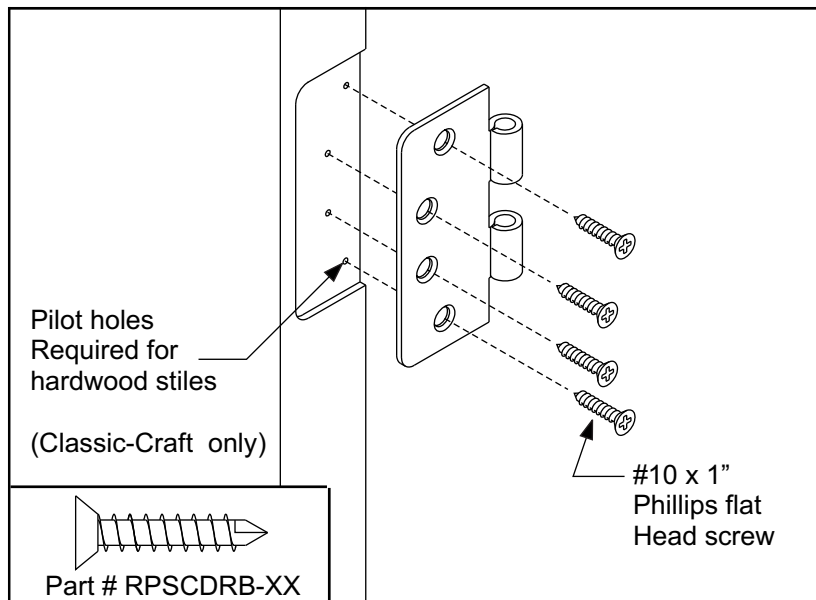

Adjustable Hinges

Required Tools

1. A 3/16" hex wrench is required.
2. A small flat head screwdriver is required.
3. A plastic putty knife is recommended to prevent damage to hinge finish.

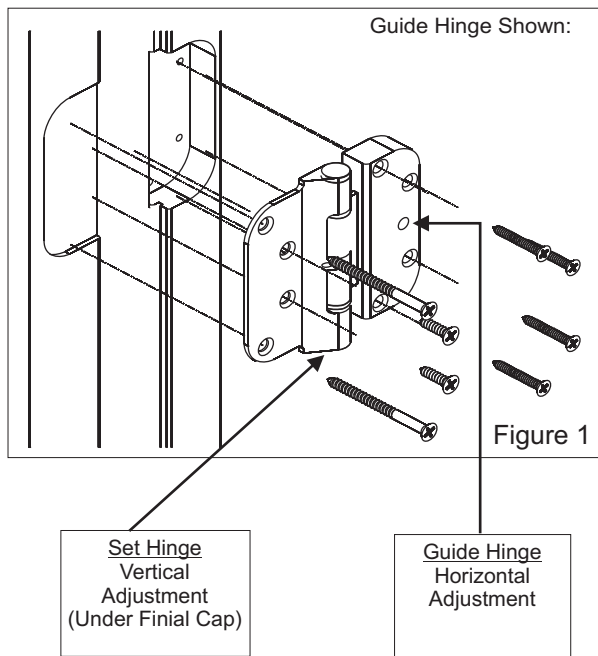

There are two types of HOPPE Adjustable Hinges on each door panel:

1. **Set Hinge:** one per panel. The set hinge provides ± 0.12 " vertical adjustment.
2. **Guide Hinge:** Two or three per panel. The guide hinges provide ± 0.12 " horizontal adjustment. The two Guide Hinges go in top and bottom locations with the Set Hinge in the center. For 8' door the Set Hinge is located second from top of door. Refer to Figure 2.

Assembly Information

1. Insert the thick side of the hinge into the hinge mortise on the door.
 2. Pre-drill 3/32" diameter pilot holes through hinge holes.
 3. Fasten with (4) #8 x 1-1/4" flat head screws refer to figure 1.
 4. Place hinges into hinge mortise on the frame.
 5. Seat hinge to back of machined hinge pocket.
 6. Fasten with (2) #10 x 3/4" flat head screws in the middle of each hinge.
- Fasten the top & bottom holes with (2) 2-1/2" flat head screws

DOOR
PREP

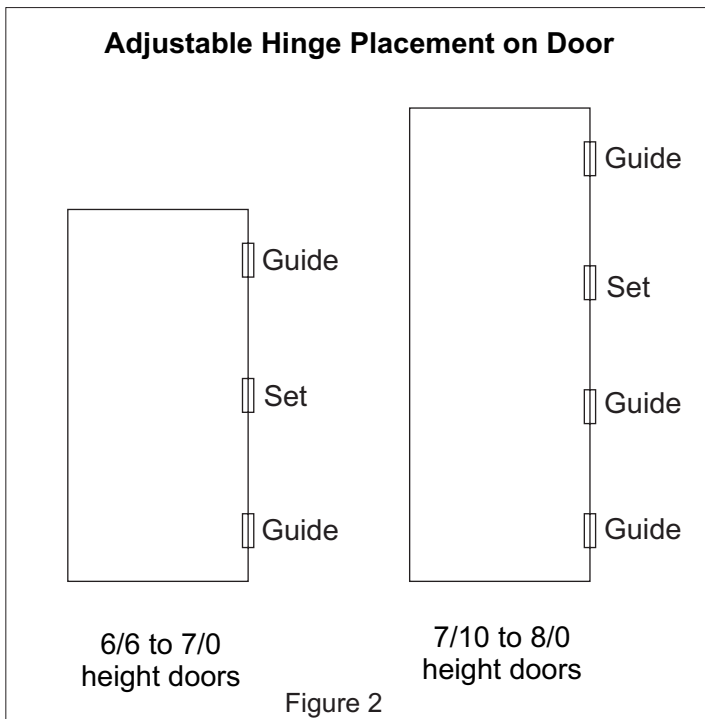

Vertical Adjustment (Set Hinge)

With the door closed or open

1. Remove the press-fit Finial Cap from the bottom of the Set Hinge to expose the adjustment screw. Use the small screwdriver for Set Hinges featuring a plastic Finial Cap. A plastic putty knife is recommended for Set Hinges featuring a brass Finial Cap.
2. Insert the hex wrench into the bottom of the Set Hinge. Turn the screw clockwise to raise the panel and counterclockwise to lower the panel.
3. Reinstall the Finial Cap.

Horizontal Adjustment (Guide Hinge)

The door must be open to access the adjustment screw.

1. Insert a 3/16" hex wrench into the horizontal adjustment screw.
2. Turn clockwise to decrease the margin and counterclockwise to increase the margin on the hinge side.

Hinge Installation

DOOR
PREP

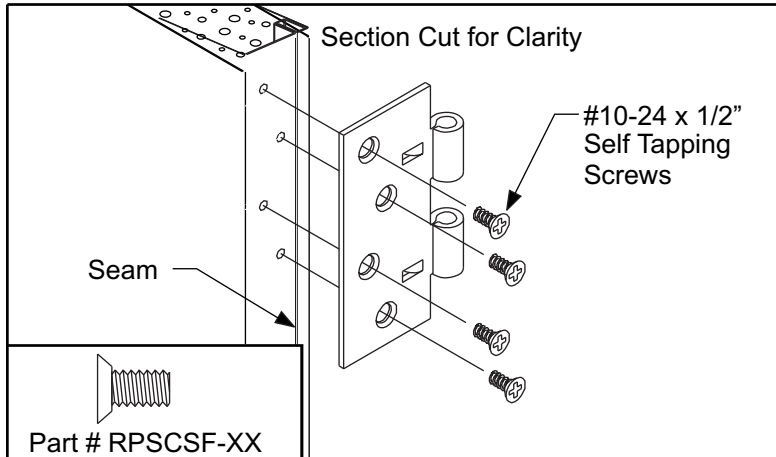

Surface-Mounted (Fire Door)

Align and Install Hinges

Use pilot holes to align 2-knuckle hinge leaves.

Fasten 2-knuckle hinge leaves with proper screws.

Considerations for Assembled Hinges

Riveted-pin hinges have locating tabs. Fasten to slabs using same method as for unassembled hinges, placing tabs against door face to locate hinge.

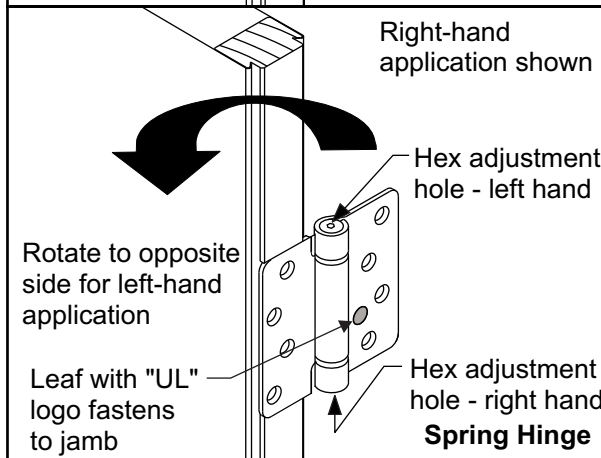
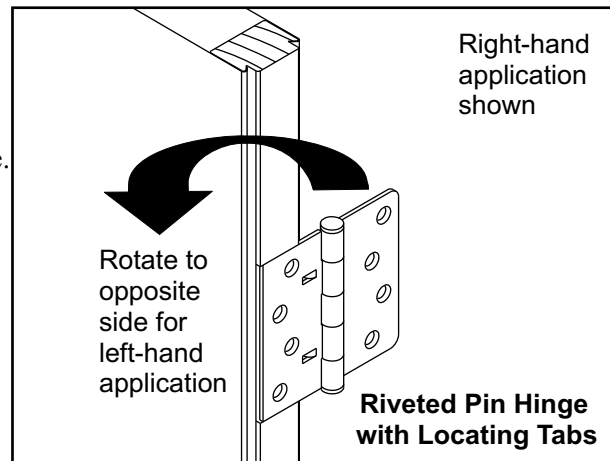
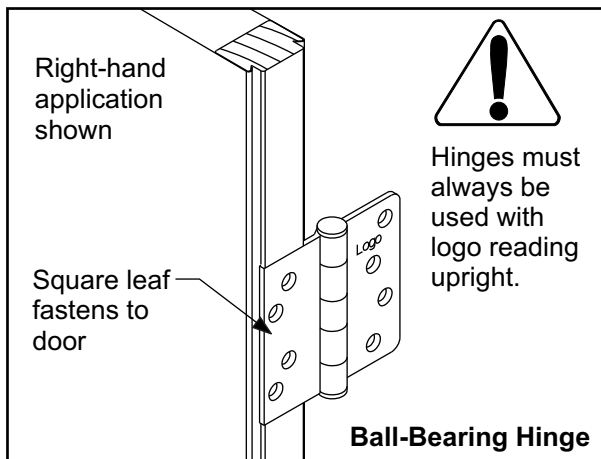

For wood-edged doors with pass-through hinge mortises, take care to place correct leaf on door edge, and fasten at correct backset, for alignment. (Backset is 1-3/8")

To apply these hinges to wood-edged doors, use a template and mark screws or bore 3/32" diameter pilot holes.

A standard hinge leaf with locating tabs can also be used as a template, if a vix-bit is used to center the pilot holes in the centers of the hinge holes.

If assembled hinges are used, fastening door slabs to frames will require that the slabs be first fastened to loose hinge jambs, with the rest of the frame and sill then being built around the slab.

Select Door Bottom

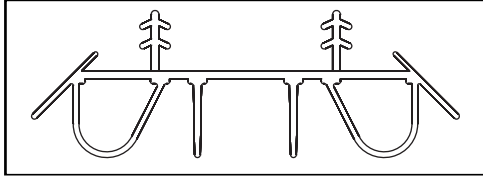

**Dual Bulbed Kerf-Applied
Door Bottom DBDB300**

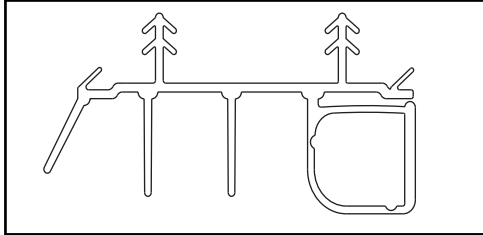

**Kerf-Applied
Door Bottom
DB30094**

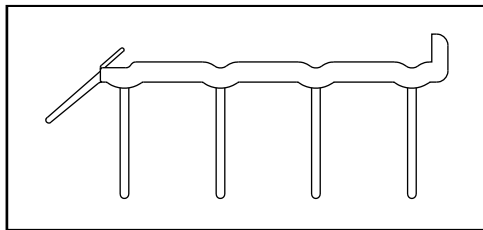

**Sweep/Replacement
Door Bottom DB30SWP**

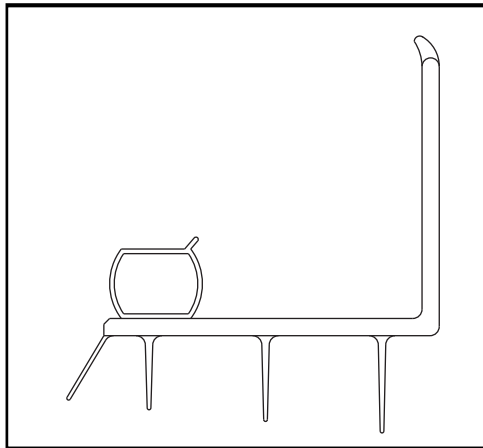

Fire Door Bottom TSA30

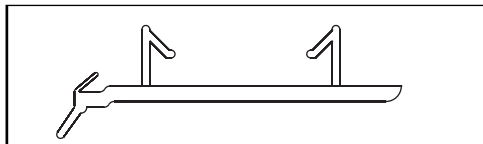

**Outswing Kerf-Applied Door
Bottom DB30OS99**

Compatible sill types:

Any Composite/Hardwood Adjustable
or Fixed Composite Inswing Sills.

Self Adjust Sill
Moderate Climate Sill
Expandable Steel Frame Sill (Inswing & Outswing)

Any sill
Public Access Sill

Primarily used as a replacement door bottom

Used on cutdown doors when kerfs are trimmed
away.

Public Access Sill
Standard Adjusta-Fit 2 Sill
Adjusta-Fit 2 Steel Frame Sill

(Recommended)
Outswing Sills with exception of Composite Fixed

DOOR
PREP

Door Bottom Selection & Installation



CAUTION:
Outswing units with bumper sills do not require door bottoms.

Kerf Door Bottoms

Caulk and Fasten Door Bottom

Select a sealant (Elastomeric or Polyurethane) that provides excellent adhesion to both plastic and wood.

Apply sealant as shown to both ends of door bottom.

Center door bottom and press into rail kerfs.

Fasten ends of door bottom with (2) 1/4" or 1/2" crown x 3/4" or 7/8" staple on each end.

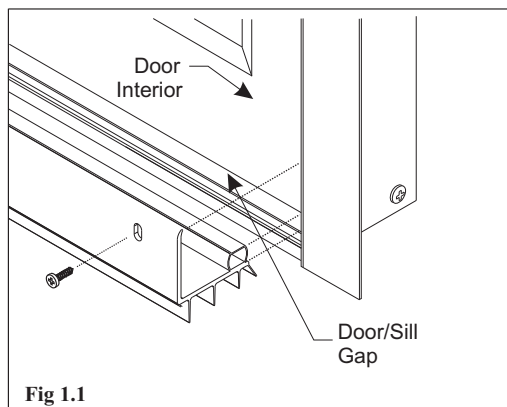
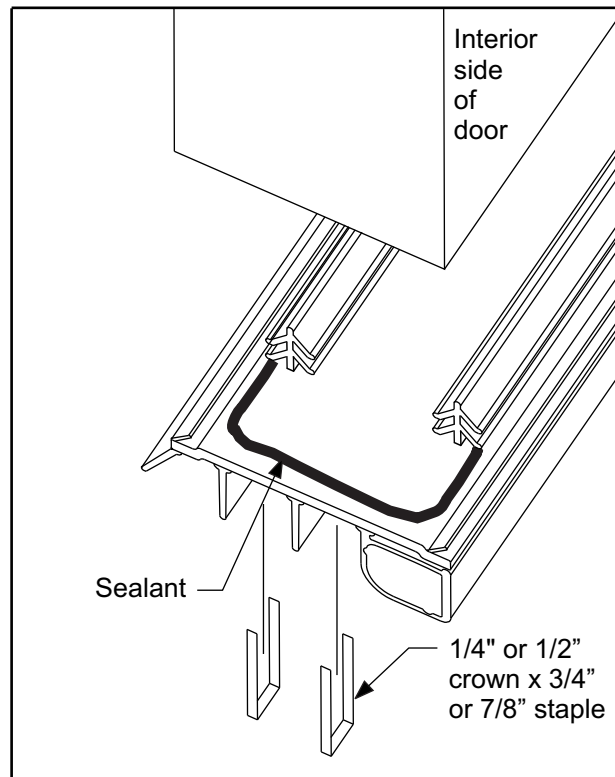
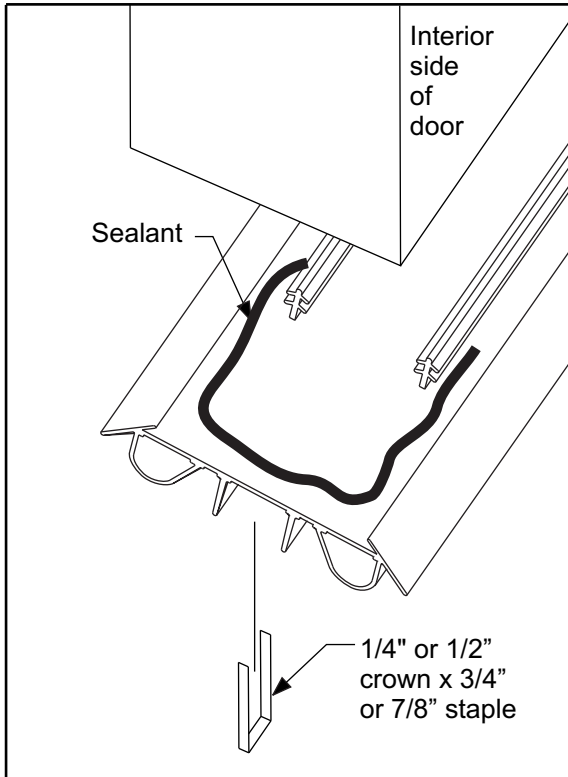

'Fire Door' Door Bottom

Fasten Door Bottom

Slide door bottom between door and sill. Align at ends and against inside face with lip. Screw door bottom in place with (5) # 8 x 1/2" self piercing spear tip screws beginning in the center and working out to ends.

DOOR
PREP

Sweep/Replacement Door Bottom

Fill Kerfs with Sealant

Fill kerfs in bottom rail with sealant (Elastomeric or Polyurethane) if working with trimmed door and shallow kerfs.

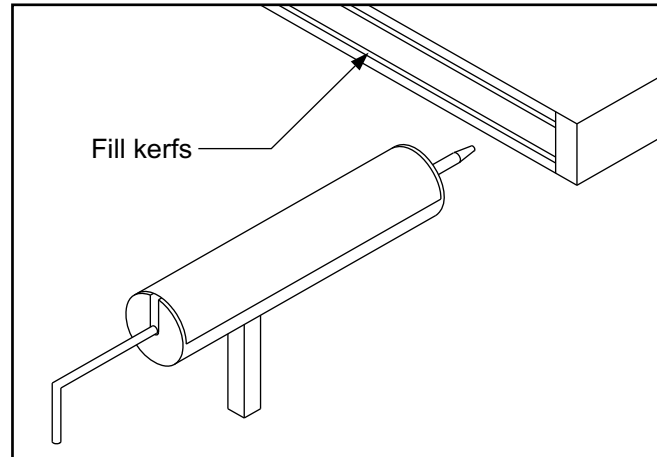

DOOR
PREP

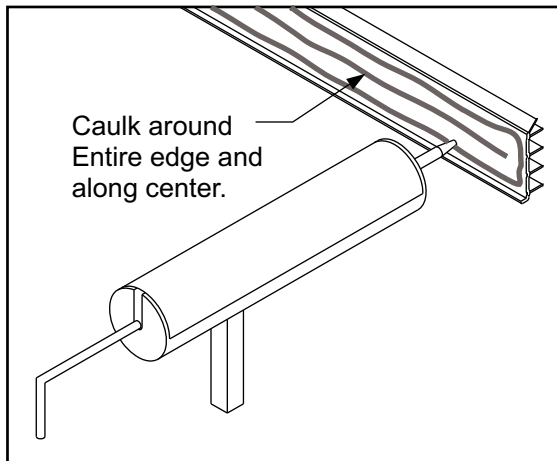

Caulk Sweep/Replacement Door Bottom

Select a sealant (Elastomeric or Polyurethane) that provides excellent adhesion to both plastic and wood.

Apply bead of sealant (Elastomeric or Polyurethane) to entire edge and center of the door.

Fasten Door Bottom

Place door bottom against rail.

Align at ends and against inside face with lip.

Staple in place, beginning at center.

Work toward each end and fasten as shown. Press flat to avoid scalloping.

Staple twice at each end as shown.

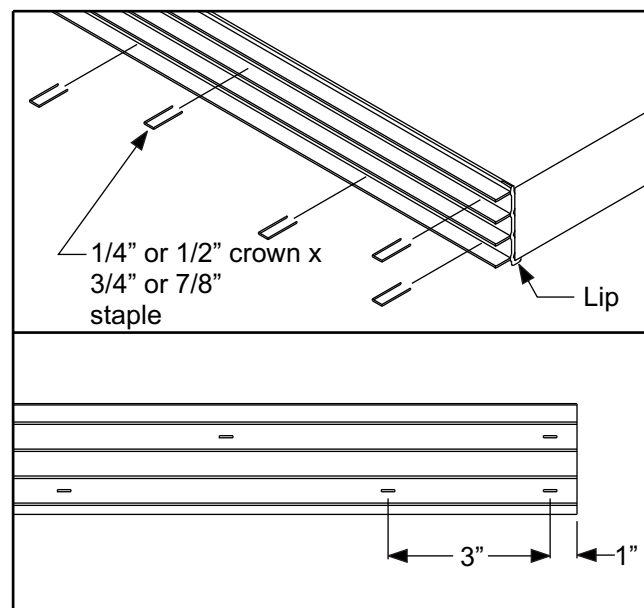

Grille Installation

Grilles come complete with clips.

DOOR
PREP

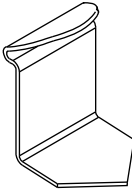
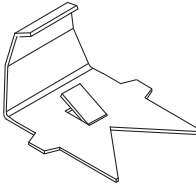
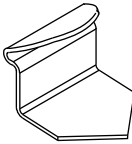
BTS	FLUSH GLAZED	CC
		
Part # RPWGMC2	Part # RPFGGC	Part # RPCGC

SPRING STEEL CLIPS

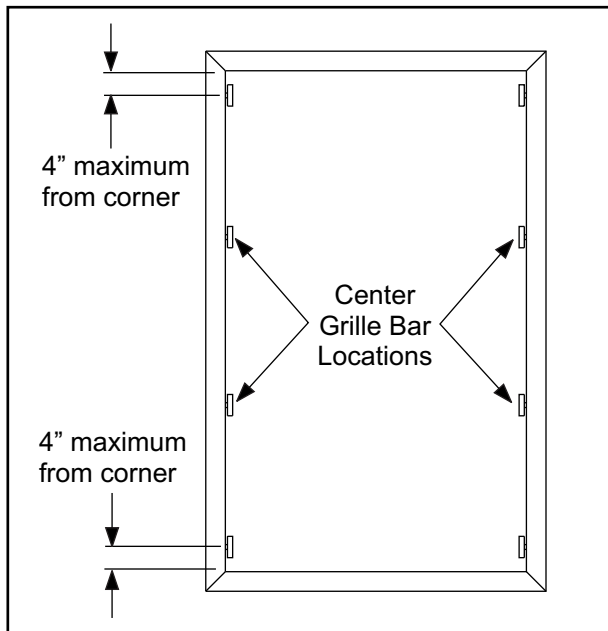

Position Clips

Locate clips on vertical sides of frames 4" maximum from each corner and at center grille bar locations.

Installation for Lite Frames

Install Clips

Loosen doorlite screws slightly.

Slide flat side of clips under interior side of doorlite frame.

Retighten screws.

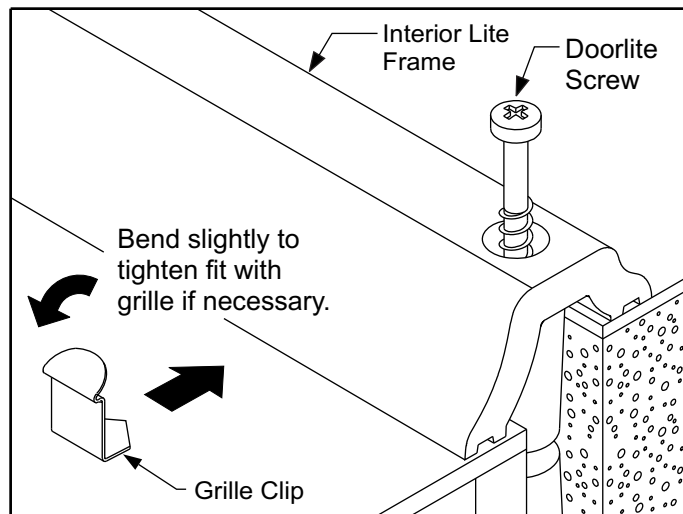

Installation for Flush-Glazed Doors

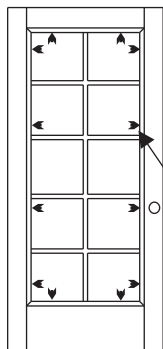

To assure proper installation, carefully remove any excess sealant at glass edge before installing grille clips.

Insert steel spring clips between stop and glass at the locations shown. **AVOID PUTTING CLIPS IN LINE WITH MUNTINS HORIZONTAL AND VERTICAL GRILLE BARS.** (Note: number of clips may vary from shown due to grille size and door style.

Use the installation tool as shown to push the clip completely into the locked position.

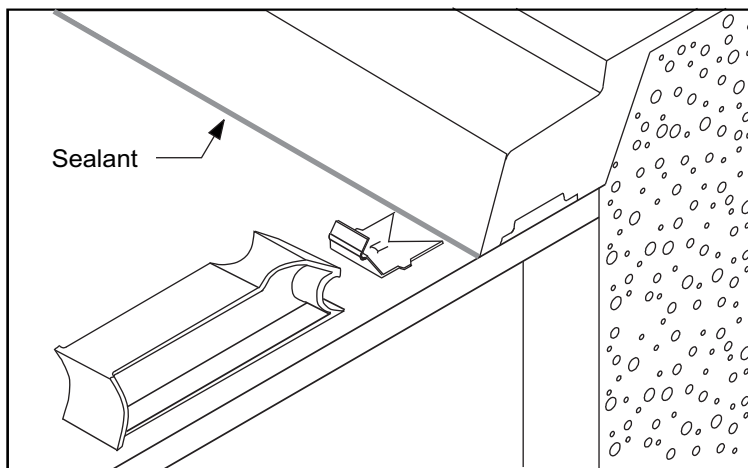

Section Cut for Clarity

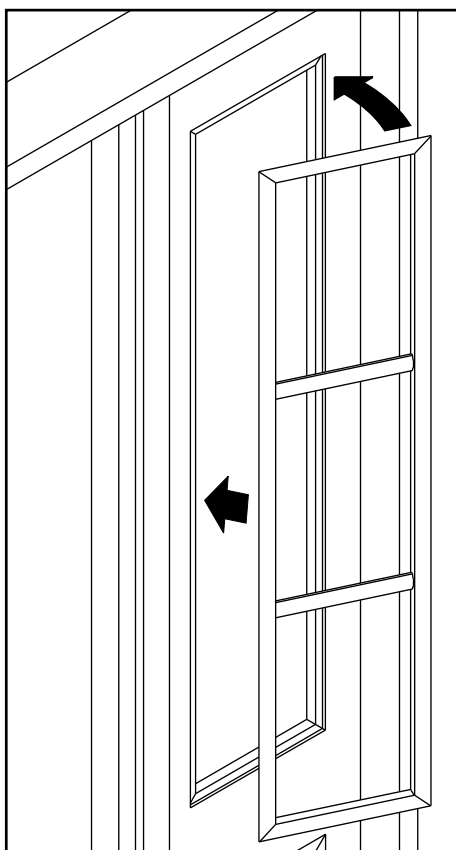

With all the clips installed, insert grille against clips on one side. Gently push opposite side of grille against glass, locking all clips into frame. Remember to gently press the top and bottom of the grille against the glass.

Clips will be hidden when grille is inserted.

To remove, gently pull away from the glass surface at one long side of the grille where the muntins meet the grille frame.

DOOR
PREP

Classic-Craft Lite Divider Installation Instructions

THERMA TRU
DOORS

NOTE: TEMPERATURE RANGE FOR OPTIMUM TAPE ADHESION IS 70° TO 100°F. MINIMUM SUGGESTED APPLICATION TEMPERATURE IS 60°F. THE DOOR AND LITE DIVIDER ARE TO BE IN THIS TEMPERATURE RANGE. ALLOW 72 HOURS FOLLOWING APPLICATION FOR FULL BOND STRENGTH ON TAPE.

DOOR
PREP

1. Moisten a clean cloth with 70% Isopropyl Alcohol. Wipe both sides of glass as shown at right. Allow to dry.



NOT PREPARING THE GLASS WILL RESULT IN POOR TAPE ADHESION.

2. Lay out dividers in desired pattern in the lite opening. For the 4- and 6-lite packs: the long dividers are placed vertically, the short dividers are placed horizontally.
3. Position template in lower left corner of lite opening (see page 2), with the top of the template (as marked) toward the top of the door.
4. Working with vertical dividers first, remove carrier backing from the divider. **NOTE: ADHESIVE IS NOT REPOSITIONABLE.**
5. Position divider, adhesive side toward the glass, using the template as a guide for placement.
6. Press firmly to the glass to secure adhesive. Note: allow 72 hours following application for full bond strength of adhesive.
7. Apply remaining dividers (repositioning the template where applicable) in the same manner.
8. Repeat the same installation steps for the other side of the door.

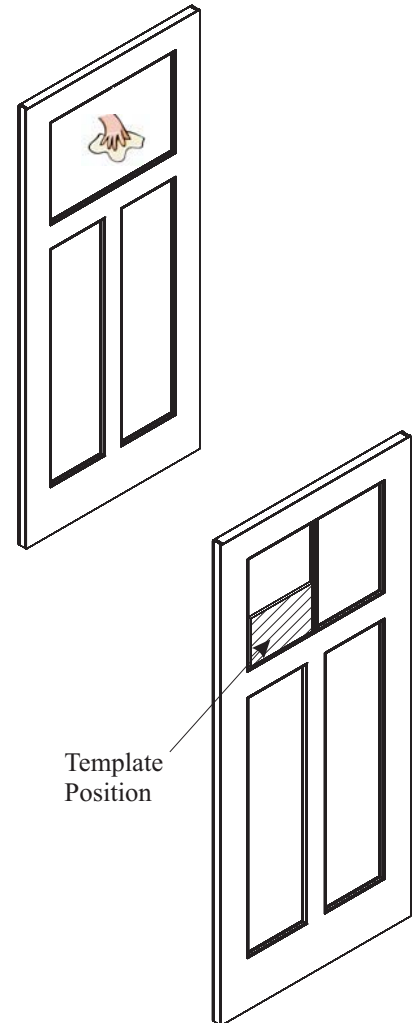

EXAMPLE

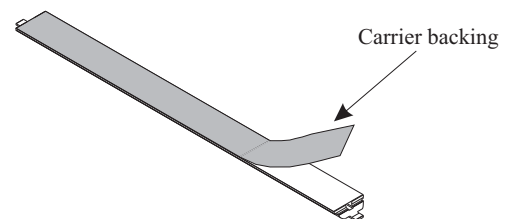

Recommendations:

Apply all vertical dividers **BEFORE** applying horizontal dividers.
Use a veneer roller over fully-positioned lite dividers to increase adhesion.

Template Part Number:
TPA2618LD2-P

Template Part Number:
TPA2618LD3-P

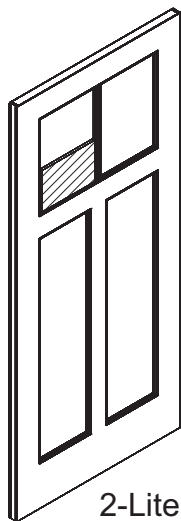

2-Lite
Template
Position

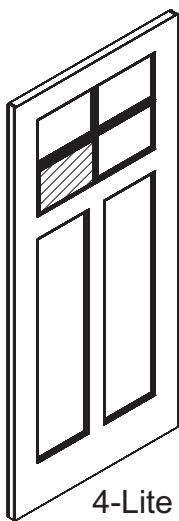

4-Lite
Template
Position

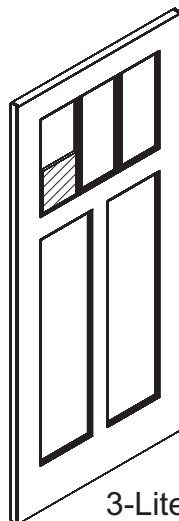

3-Lite
Template
Position

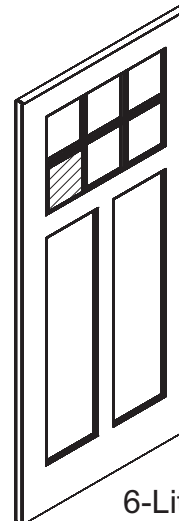

6-Lite
Template
Position

DOOR
PREP

Template Part Number:
TPA0866LDSL5-P

Template Part Number:
TPA0880LDSL6-P



5-Lite
6'8" Sidelite
Template Position



6-Lite
8'0" Sidelite
Template Position

Smooth Star / Fiber Classic Craftsman Lite Divider Installation Instructions

DOOR
PREP

NOTE: TEMPERATURE RANGE FOR OPTIMUM TAPE ADHESION IS 70° TO 100°F. MINIMUM APPLICATION TEMPERATURE IS 60°F. BOTH THE DOOR AND LITE DIVIDER ARE TO BE IN THIS TEMPERATURE RANGE. ADHESIVE IS NOT REPOSITIONABLE.

Glass Preparation:

1. Moisten a clean cloth with 70% Isopropyl Alcohol or use a silane adhesion promoting solution. Wipe one side at a time, before attaching dividers to that side. Allow to dry.



NOT PREPARING THE GLASS WILL RESULT IN POOR TAPE ADHESION. DO NOT USE A GLASS CLEANER AS THIS WILL PREVENT ADHESION.

2, 3, 4 and 6 Lite Divider Patterns:

1. Starting at the external glass side, take a horizontal divider and place it at the top of the glass. Use the notch(es) on the divider to mark on the frame the top position of the vertical divider(s).
2. Take a vertical divider, and use the end point and notch to mark on the frame the left and right hand positions for the horizontal divider(s).

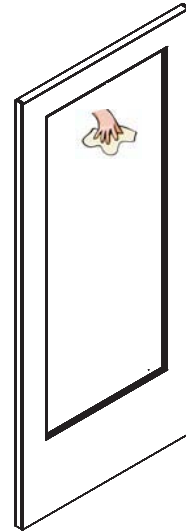

3. Remove the dividers from the glass. Assemble the horizontal and vertical divider(s). Use masking tape to tape the divider bars across the top to hold them together. Peel off the Carrier Backing from all of the divider pieces. Lightly place the tips of small zip ties or coffee stirrers roughly 1/8" onto the adhesive backs as shown. For each of the divider bars, position 1 tie at each end of the divider, and 1-2 ties in the middle. The ties will keep the adhesive backing off of the glass during final positioning.

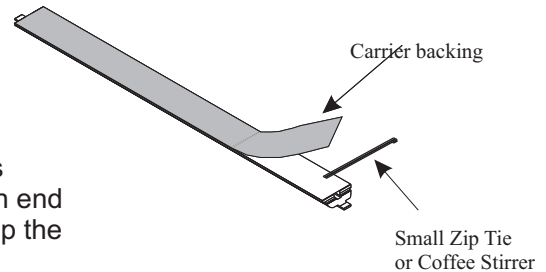

4. Position the divider back onto the glass using your frame position marks. Check to ensure that for all of the frame to divider points, that there is a .015-.020" gap between the divider and the frame (use a card or credit card). Once in position, press down at all of the ends opposite the zip tie to lock the position, and then pull out that zip tie. Once all of the divider ends are attached, pull out the middle zip ties from the dividers. Roll or press down firmly along the entire length of the horizontal and vertical dividers. Look through the interior side to confirm all dividers adhesion to the glass, particularly around the perimeter and divider joints. Once attached, remove the masking tape.
5. Repeat the Glass Preparation and Steps 1-4 for the interior dividers. Check the alignment of the interior dividers with the exterior dividers before attaching the interior dividers. Allow 72 hours following the application for full bond strength.

RECOMMENDATIONS:

Use a veneer roll over fully-positioned lite dividers to increase adhesion. Recommend a "J" roller style with a 10 in minimum arm length.

Zip Tie Patterns

2-Lite Pattern

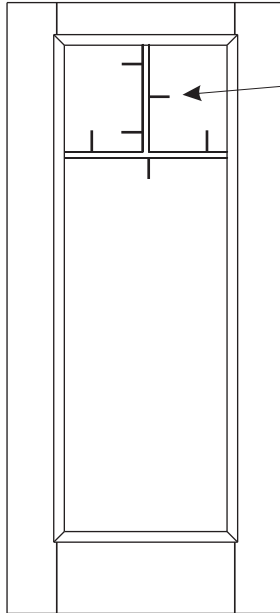

Zip Ties
(6 min)

4-Lite Pattern

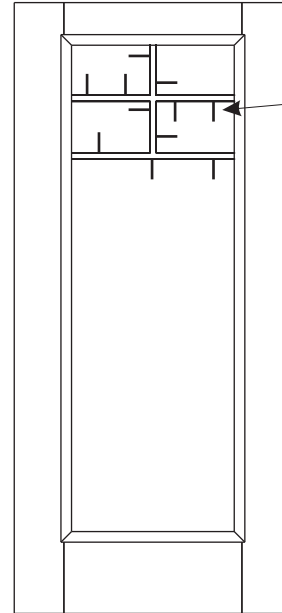

Zip Ties
(11 min)

DOOR
PREP

3-Lite Pattern

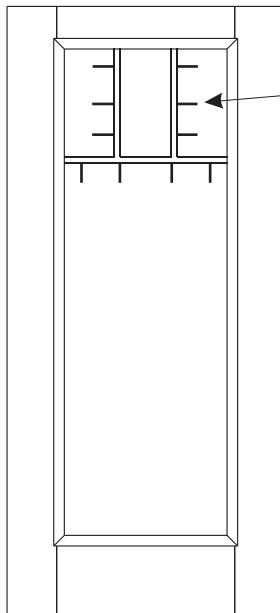

Zip Ties
(10 min)

6-Lite Pattern

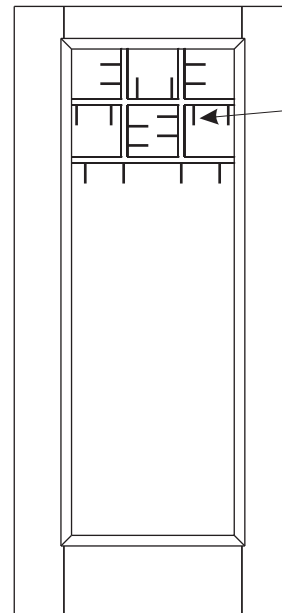

Zip Ties
(18 min)

DOOR
PREP

Shop Installation Instructions for Dentil Shelf Attachment

The following instructions should be completed in the door shop or at the job site. Check to see that the shelf shop pack is included with this unit. The pack contains all the necessary hardware and fasteners needed to complete this installation.

Read all instructions before starting.

THERMA TRU[®]
DOORS

The Most Preferred Brand in the Business™

Part Number: MACCASHELFINST REV.B

1 APPLY LOCATING TEMPLATE TO DOOR

Apply shelf locating template to door slab. Align all three sides of the template to ensure it is squared up with the door. Hold template down with clamps if needed.

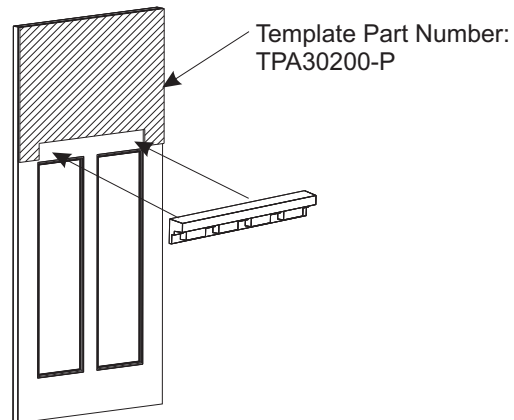

2 DRILL PILOT HOLES

After getting shelf aligned with the template, drill pilot holes with 1/8" drill bit at all three attachment locations into wood block on inside of the door.

Holes to be approximately 1/4" to 1/2" in depth. CAUTION: DO NOT DRILL THROUGH ENTIRE DOOR.

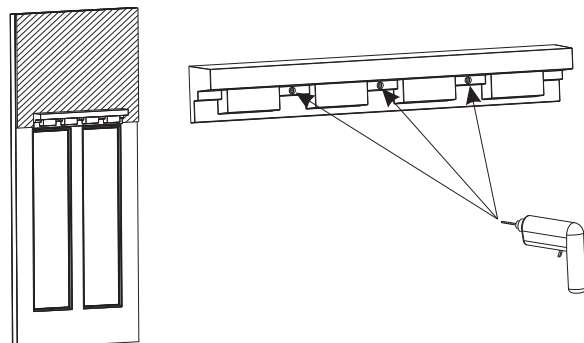

3 FASTEN SHELF TO DOOR

Fasten three screws into door at screw boss locations until shelf becomes tight with door. DO NOT OVER TIGHTEN.

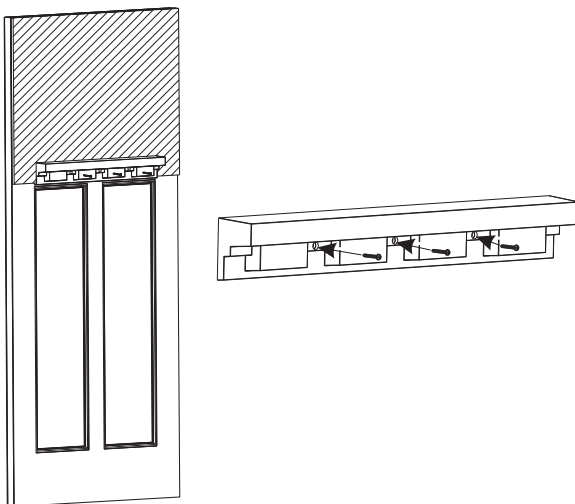

4 INSERT PLUGS

Align grain and insert plugs into holes. Press until plug is flush with shelf surface.

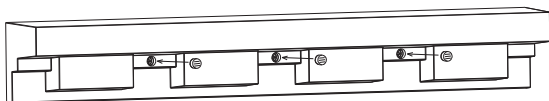

DISCLAIMER: SHELF IS NOT INTENDED TO HOLD ANY OBJECTS OR WEIGHT.

Shelf Installation Components

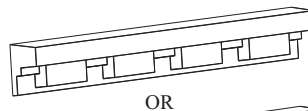

OR



Dentil Shelf
CCADS04 OR CCADS16

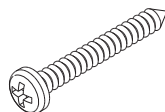

Shelf Screw
(3) #10 x 1-1/2"
Phillips Pan Head



Shelf Plug
(3) Plugs
CCAPLUG

DOOR
PREP

THERMA TRU
DOORS

The Most Preferred Brand in the Business™

P.O. Box 8780
Maumee, Ohio 43537
419-891-7400

Therma-Tru is a registered trademark of Therma-Tru Corp.
© 2005 Therma-Tru Corp.

Fiber Classic And Smooth Star Dentil Shelf Installation Instructions

IMPORTANT:

Please read and understand all installation and adhesive instructions prior to opening the adhesive cartridge.

CAUTION: Make sure your work area is well ventilated. Keep adhesive away from heat and flame. Avoid any contact with the eyes and skin. Read warning label on adhesive box. KEEP OUT OF REACH OF CHILDREN.

NOTES:

- When PAINTING, the door and dentil shelf should be unfinished when applying dentil shelf.
- When STAINING, the door and dentil shelf should be finished before applying the dentil shelf
- To be removed from the opening and placed in a horizontal position for a minimum of three hours to allow the adhesive to cure.

TOOLS NEEDED: Safety Glasses, Latex Gloves, Mineral Spirits, Soap and Water, Stir Stick, Bristle Brush, and Disposable Container for mixing.

INSTALLATION:

STEP 1: PREPARE THE DOOR

Protect the underside of the door by laying it flat on padded sawhorses or another padded surface. Position the door with the exterior side facing up. Thoroughly clean the door surface and the dentil shelf with soap and water. Be sure to thoroughly rinse with water to make sure all soap and residue are removed and then dry completely. Surface must be completely dry before going on to Step 2.

STEP 2: LOCATE SHELF

Position the dentil shelf on the door so that it is centered along the width of the door and parallel to the glass opening (suggested location is 3/8" from the bottom of the glass). With a graphite pencil, lightly mark the locations of the top and sides of the shelf on the door face.

STEP 3: APPLY ADHESIVE

Open adhesive cartridge as directed in the "DIRECTION FOR USE" instructions on the inside of the adhesive package. Dispense adhesive cartridge into a disposable container and mix thoroughly with a clean stir stick for thirty seconds. Using a bristle brush, apply a thin coat of adhesive to the wood core on the underside of the shelf. Be careful not to allow adhesive on the sides of the shelf. The coating should not be more than 1/16" thick and should be approximately 1/2" away from all edges to help prevent squeeze-out. Carefully press the shelf onto the door face using your pencil lines (from Step 2) as your locating guides. Apply firm pressure to ensure contact with door. You will have approximately 3 to 4 minutes to work with the shelf before the adhesive starts to set. Immediately remove any adhesive squeeze-out with mineral spirits and a clean cloth.

STEP 4: CURE TIME

The shelf and door should remain in the horizontal position for a minimum of three (3) hours to allow the adhesive to cure. After three hours, the door can be finished if painted or re-installed if staining. Full bond strength is reached at sixteen (16) hours.

STEP 5: ADHESIVE DISPOSAL

Wipe tip clean, retract plunger slightly and close with the special cap. Allow the adhesive in the disposable container to harden in a well ventilated area. Once hardened, properly dispose of adhesive.

DISCLAIMERS:

- **SHELF IS NOT INTENDED TO HOLD ANY OBJECTS OR WEIGHT.**
- **THE SHELF IS NOT RECOMMENDED FOR USE BEHIND A STORM DOOR.**

Therma-Tru products are manufactured for use with high quality, exterior grade house paints. See SITE 2 for standard finishing instructions. For distributor furnished prefinishing, use the following guidelines.

**CAUTION:**

Therma-Tru bears no responsibility for the performance of distributor-furnished prefinished doors.

Therma-Tru makes no claims about the compatibility of its primers when coated with special shop applied paints or topcoats.

DOOR
PREP**Finishing With Materials Other Than High Quality, Exterior Grade House Paints**

Automotive and industrial paints often contain stronger solvents than house paints. Because Therma-Tru's factory applied primer is intended for use with house paints, these stronger solvents may attack the factory applied primer. For best performance, we recommend:

STEEL

- Use a water-based acrylic paint, instead of an epoxy or urethane.
- If using an epoxy or urethane paint, first apply a primer over the factory applied finish. The primer will act as a barrier between the factory applied finish and the topcoat. The primer must, of course, be compatible with the topcoat being used.

CLASSIC-CRAFT, FIBER-CLASSIC and SMOOTH-STAR DOORS

- Use a water-based acrylic or alkyd-based (oil) paint, instead of an epoxy or urethane.
- Always apply a primer. The primer will act as a barrier between the factory finish and the topcoat. Use primers and topcoats that are compatible.
- Maximum temperature for quick dry should be 200°F or less.

Special Shop Machining

Peep Sights

Two examples of Peep sights are shown below.
Peep sights vary by door style.
Please contact technical service for specific door information.

DOOR
PREP

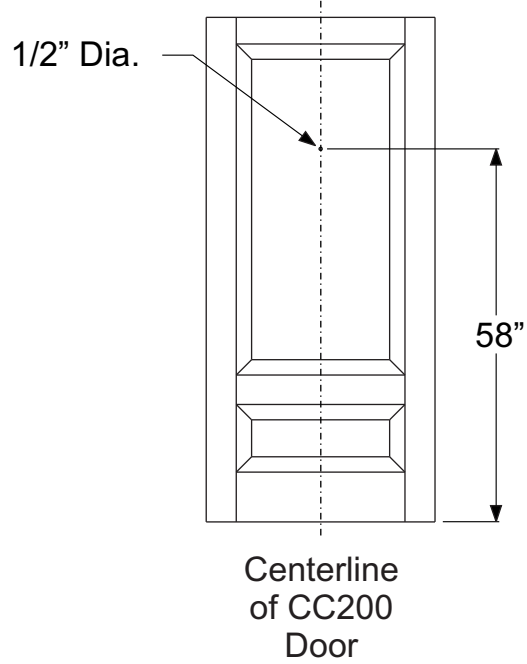
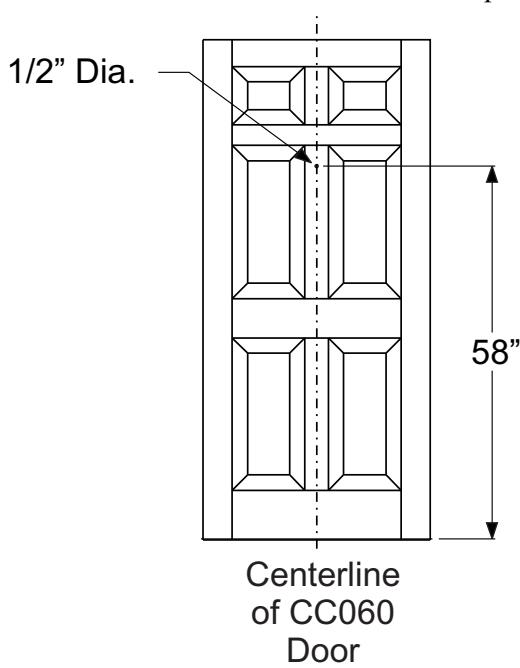

Mail Slots

Two examples of Mail slot machining are shown below.
Mail slot locations vary by door style.
Please contact technical service for specific door information.

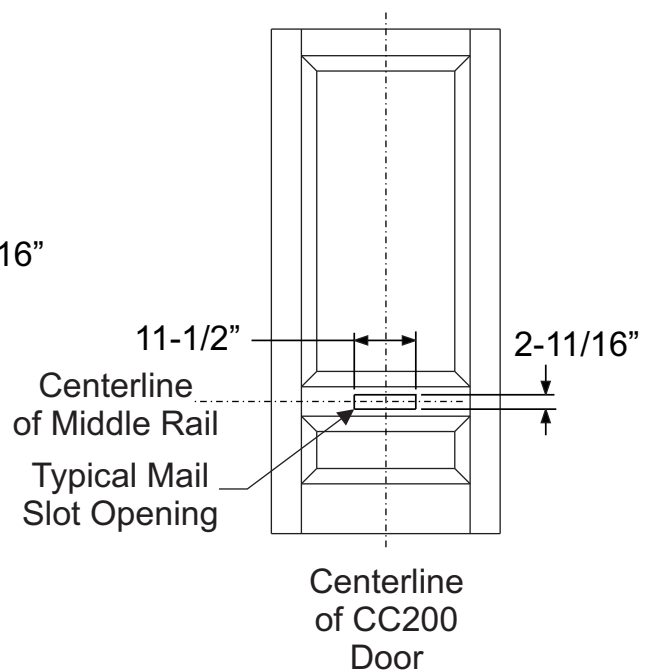
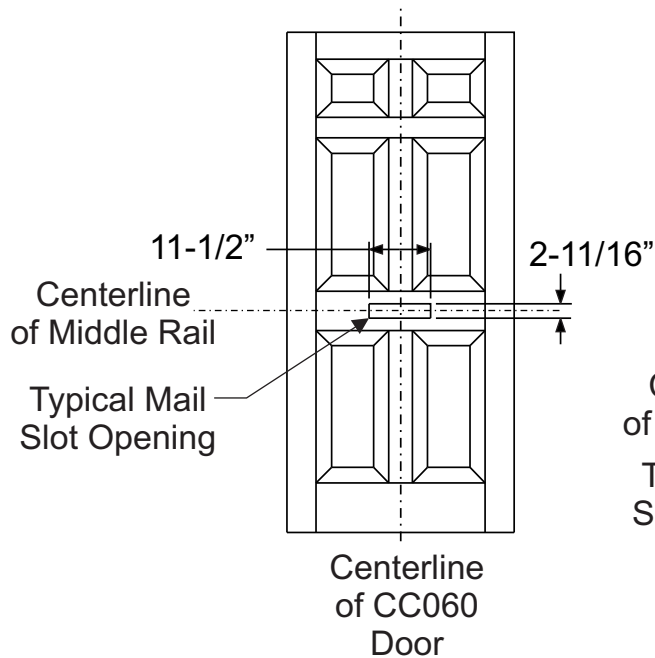

Attach Rain Deflector



Sealant type must be a paintable/stainable elastomeric or polyurethane.

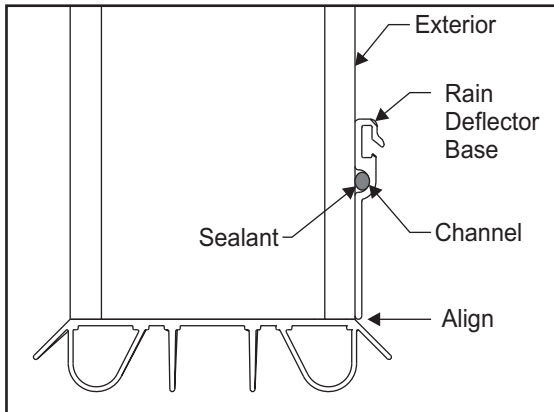

Center rain deflector base on exterior face of panel and align edge of rain deflector base with bottom edge of panel.

Apply bead of sealant in channel on rain deflector base.

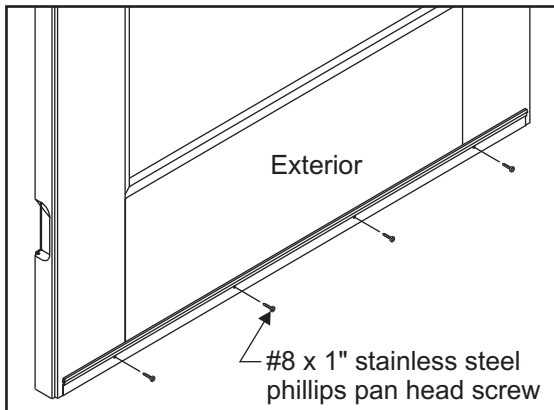

Attach rain deflector base to panel with #8 x 1" phillips pan head screws.

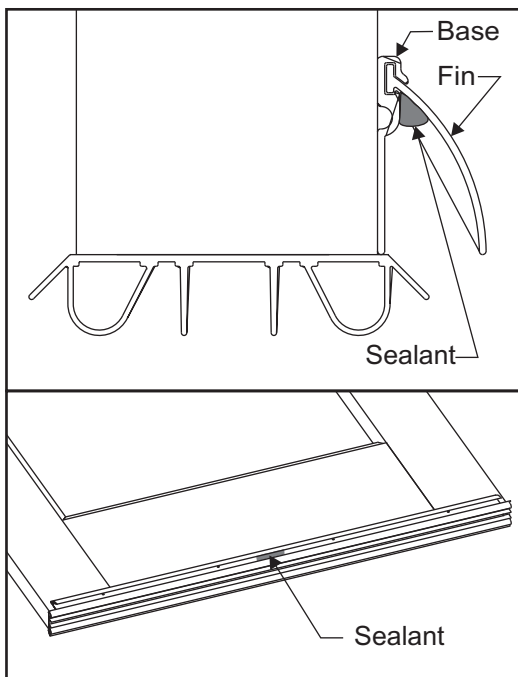

Slide rain deflector fin into channel on base.

Apply a 2" long bead of sealant up under the fin at the center of the door to prevent fin from sliding.

DOOR
PREP

DOOR
PREP

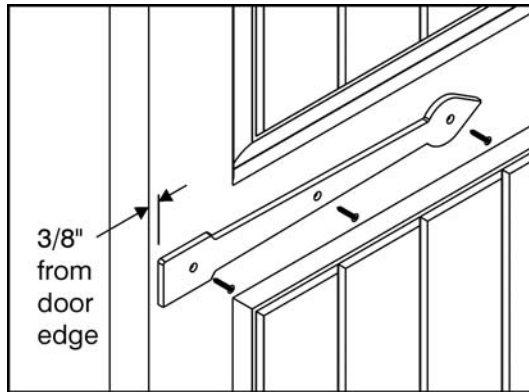

INSTALLATION:

1. Locate strap hinges 3/8" from edge of door at desired locations.
2. Mark holes at screw locations.
3. Drill 1/16" holes thru door skin.
4. Dab drilled holes with sealant or epoxy.
5. Fasten strap hinges with #8 screws.
DO NOT seat screws with power driver.
HAND TIGHTEN ONLY.
DO NOT OVER-TORQUE.
6. Wipe off any access sealant or epoxy.

INSTALLATION INSTRUCTIONS

(INCLUDE WITH EVERY PACK OF 3 STRAPS)